



Automated Glass Coverslipper

**Operating
Manual**

© 2010 Sakura Finetek USA, Inc.

All Rights Reserved
Printed in U.S.A.



Manufactured for:

Sakura Finetek USA, Inc., Torrance, CA 90501 U.S.A.

Sakura Finetek Japan Co., Ltd., Tokyo, 135-0007, Japan

Sakura Finetek Europe B.V., 2804 AV Alphen aan den Rijn, NL

Made in Japan

0002783-01 Rev.B

TABLE OF CONTENTS

<i>Section</i>		<i>Page</i>
1	INTRODUCTION	
	Safety Precautions	1.1
	General Description	1.2
	Physical Characteristics	1.3
	Specifications	1.7
2	INSTALLATION	
	General Information	2.1
	Environmental Factors.....	2.1
	Unpacking	2.1
	Installation of Accessories and Consumable Supplies	2.3
3	CUSTOMIZATION OF SETTINGS	
	General Information	3.1
	Explanation of the Main Menu.....	3.1
4	OPERATING INSTRUCTIONS	
	Operating Instructions.....	4.1
	Routine Operations	4.5
	Start of Operation	4.5
	Operations Permitted during Operation.....	4.9
	End of Coverslipping	4.11
	End of Operation	4.12
	What to do before Prolonged Period of Non-operation	4.12
	Actions to Be Taken upon Power Outage during Operation.....	4.13
	Table of Coverslipped Conditions and Remedial Actions	4.14
	How to Operate the g2 when Linked to the Prisma	4.17
5	CARE OF INSTRUMENT	
	General Maintenance.....	5.1
	Inspection Methods and Cleaning	5.1

TABLE OF CONTENTS

Section		Page
6	TROUBLESHOOTING	
	General Information	6.1
	Troubleshooting Table.....	6.2
	Actions to take upon Generation of Errors, Cautions, and Warnings	6.3
<hr/>		
A	APPENDIX A GLOSSARY	
	Glossary	A.1
<hr/>		
B	APPENDIX B WARNINGS AND CAUTIONS	
	Warnings.....	B.1
	Cautions	B.2
<hr/>		
C	APPENDIX C NOTES ON USE	
	Notes on Use.....	C.1

INTRODUCTION

Safety Precautions

Operation of the Tissue-Tek® Glas™ g2 Automated Glass Coverslipper requires expert knowledge of the target application as well as method of use. To use the system correctly and safely, designate a “Lead System Operator.”

When the system is delivered, the Lead System Operator should receive explanation on the handling of the system directly from the sales representative.

- Read this “Safety Precautions” section beforehand to ensure the correct use of the system.
- The cautionary instructions provided herein are intended to ensure that the system will be used safely in a manner preventing the operator from injury and property damage. These instructions provide important safety information that must be heeded at all times.
- Images shown in the manual may partially differ from those of the actual product.
- In this manual, instructions pertaining to different levels of potential hazards are classified as warnings, cautions, and notes and are indicated under “Warning,” “Caution,” and “Note,” respectively. Each class of instructions is defined below.

NOTES, CAUTIONS, WARNINGS, and other safety related labeling are provided throughout this manual to indicate levels of potential hazards as defined below:

- NOTE** Indicates a reminder or other helpful information.
- CAUTION** Indicates a potential hazard in which failure to follow instruction may result in damage to the Tissue-Tek® Glas™ g2 and/or other property, or may give poor processing results.
- WARNING** Identifies a potential hazard in which failure to follow instructions may result in serious injury to the operator and/or other personnel.

The symbols used on the labels attached to the system are explained below. Labels bearing one of the following symbols provide particularly important information to know in order to ensure safety of the operator, improve work efficiency, and protect the system from damage. Be sure to check these labels and understand the specified instructions before commencing any work.

HOT SURFACE Indicates hot surfaces. Take precautions to prevent burns.



BIOHAZARD Possibility of infections depending on the type of specimens processed. Prevent infections by using Personal Protective Equipment (PPE) as required by OSHA and any applicable state or local regulations.



A label bearing this symbol specifies a cautionary item. Improper handling against the instruction may put the operator in danger or damage the system. Always follow the instructions.



A label bearing this symbol specifies an action that must be taken. Always follow the instructions.



A label bearing this symbol specifies a prohibited item. Always follow the instructions.

INTRODUCTION

General Description

The automatic coverslipper Tissue-Tek® Glas™ *g2* (Figure 1-A) is a system that dispenses mounting medium onto stained histopathological and cytopathological samples on glass slides and coverslips the samples using cover glasses.

- Up to 240 slides (corresponding to 12 baskets) can be coverslipped in a continuous manner.
- The dispense volume of mounting medium and coverslipping speed can be adjusted in real time.
- Different dispense volumes of mounting medium and coverslipping speeds can be programmed according to different tissue thicknesses.
- For best results, it is recommended to use the Tissue-Tek® Glas™ Mounting Medium, product code 6419 (Bottle size is 500 mL).
- Drying fans are provided to reduce the drying time after coverslipping.
- Activated carbon filters can be used to minimize hazardous fumes.
- Using an optional link system, link the *g2* with an automatic slide strainer (Tissue-Tek® Prisma®), to achieve automation of all tissue operations from staining to coverslipping.



Figure 1-A

Physical Characteristics

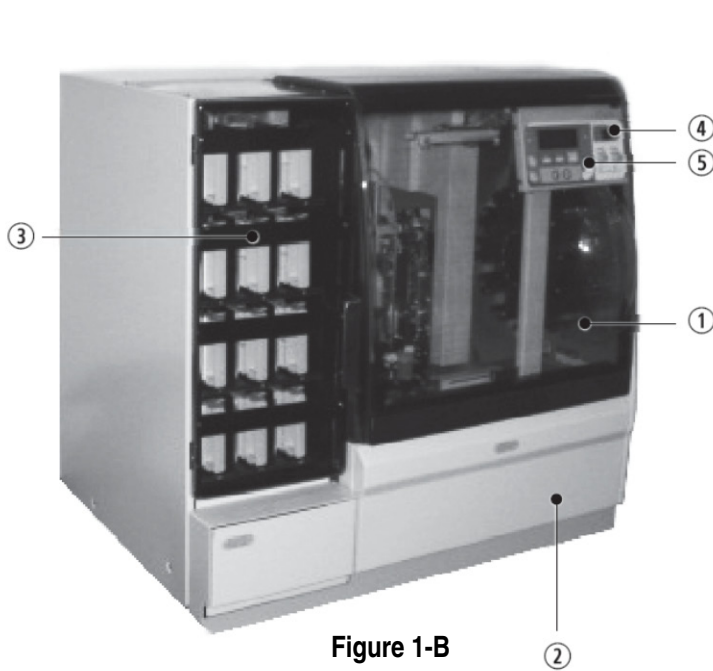

Figure 1-B

Front Side (Figure 1-B)

Cover 1 — Open this cover to fill cover glass or remove an empty basket.

Loading station access door 2 —The loading station in which baskets are placed is found behind this door.

Unloading door 3 —Receiving racks are placed behind this door.

Power switch 4 —This switch is used to turn the system power on/off.

Control panel 5 — This control panel is used to operate the system.



Figure 1-C

Back Side (Figure 1-C)

Exhaust outlet 6 —Air from the interior of the system is exhausted through this outlet. An external exhaust duct of a diameter of 38 mm or 75 mm in size can be connected.

Circuit protector 7 —This is a safety component used to protect against power surge.

Power inlet 8 —Connect the power cable here.

Contact terminal 9 —When the system is linked to an automated stainer, these terminals connect to the link cable.

Serial number label 10 — The serial number of the system is specified on this label.

INTRODUCTION

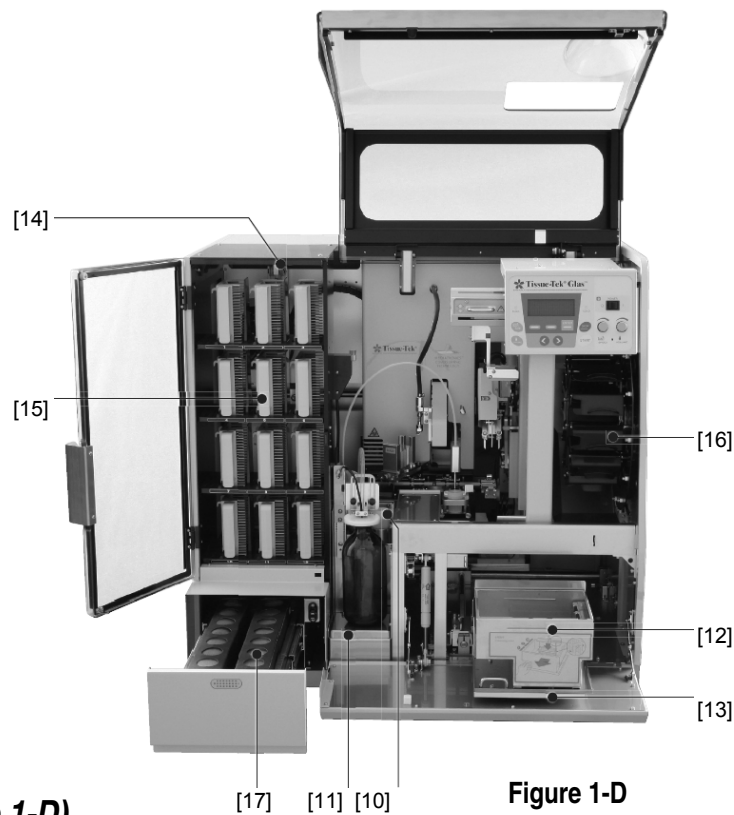

Instrument Interior (Figure 1-D)

Mounting medium bottle area 11 —A 500 mL bottle containing mounting medium must be placed in this area. For best results, use the Tissue-Tek® Glas™ Mounting Medium, product code 6419.

Loading station 12 —A xylene station in which baskets are placed. The loading station can accommodate up to three baskets.

Loading station receiver 13 —The base that facilitates smooth removal and insertion of the loading station.

Unloading area 14 —Receiving racks are placed in this area. Up to 12 receiving racks can be placed.

Receiving rack 15 —Slides that have been coverslipped are automatically placed in each receiving rack.

Carousel (empty basket carousel) 16 — After coverslipping, empty baskets are placed here. The carousel can accommodate up to 12 baskets.

Fume control (activated carbon filter drawer) 17 — Activated carbon filters that adsorb the fumes generated from the system are installed here.

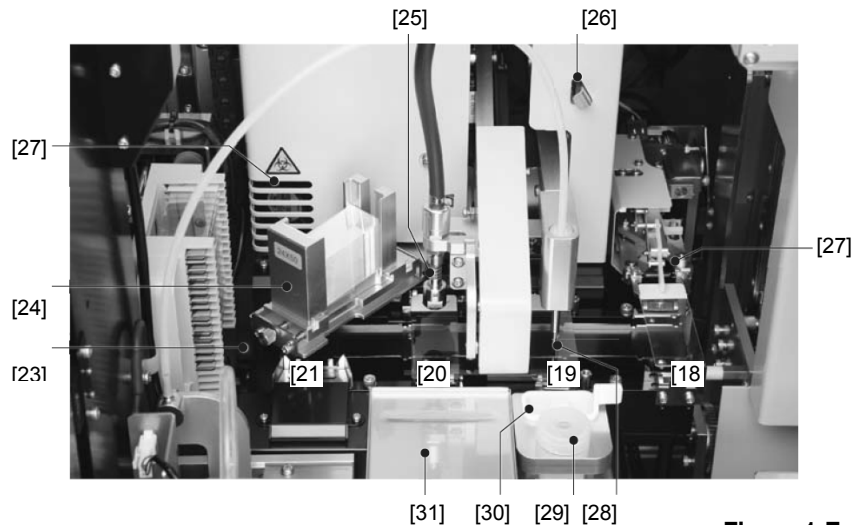

Figure 1-E

Instrument Interior (Figure 1-E)

Station 1 (slide retrieval) 18 — The slide retrieval arm takes out slides from the baskets and places them in this station. The slides that have been taken out from the baskets are moved to station 2.

Station 2 (dispensing) 19 — At this station, mounting medium is dispensed onto slides through the dispensing nozzle. After mounting medium has been dispensed onto the slides, the slides are moved to station 3.

Station 3 (coverslipping) 20 — At this station, cover glasses are picked up and carefully placed onto slides. The coverslipped slides are moved to station 4.

Station 4 (storage) 21 — At this station, coverslipped slides are placed in receiving racks.

Drying fan 1 22 — This fan removes excess xylene after coverslipping to promote the drying of mounting medium.

Drying fan 2 23 — This fan removes xylene attached to the back of the slide to promote the drying of the back of the slide.

Cover glass holder 24 — Cover glasses are placed in this holder.

Cover glass arm 25 — This arm picks up and retrieves cover glasses one at a time and places them onto slides.

Dispensing nozzle down lever 26 — This lever is used to lower the dispensing nozzle and dip it in the anti-drying bottle.

Slide retrieval arm 27 — This arm grabs each slide and retrieves it from a basket.

Dispensing nozzle 28 — This nozzle dispenses mounting medium. The dispensing nozzle moves linearly to dispense mounting medium onto a slide along a straight line.

Waste container 29 — This container is used to remove the excess mounting medium from the tip of the dispensing nozzle.

Anti-drying bottle 30 — The tip of the dispensing nozzle sits in this bottle when the instrument is idle. Put solvent for mounting medium (xylene is recommended) in this bottle to prevent the tip of the nozzle from clogging.

Dispensing pump reservoir 31 — Put solvent for mounting medium (xylene is recommended) here to prevent mounting medium from sticking to the interior of the pump.

INTRODUCTION

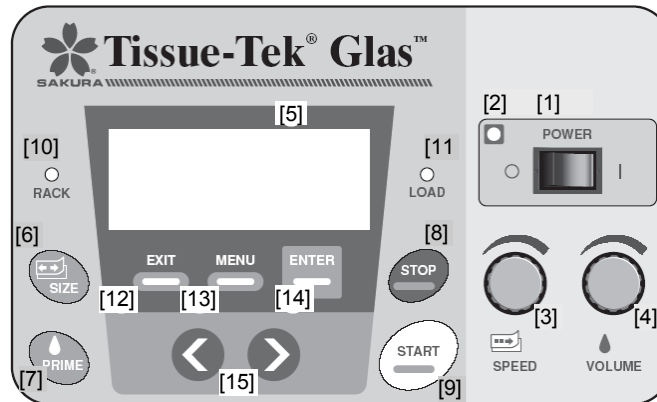

Figure 1-F

Control Panel (Figure 1-F)

POWER switch 1 — This switch is used to turn the power on/off.

POWER lamp 2 — This lamp remains on while the power is on.

SPEED setting knob 3 — A rotary switch for changing the coverslipping speed. The coverslipping speed can be changed to one of eight levels from 1 (lowest speed) to 8 (highest speed).

VOLUME setting knob 4 — A rotary switch for changing the amount of mounting medium dispensed. The volume of mounting medium can be changed to one of 10 levels from 30 μL to 120 μL .

Display screen 5 — The main screen that shows the current system status and other information required for operation.

SIZE key 6 — The size of cover glass can be changed using this key. The four sizes of cover glass are 40, 50, 55, or 60 mm.

PRIME key 7 — Press this key once, and mounting medium will be dispensed by the specified volume. Press and hold the key for 3 seconds or more, and mounting medium will be dispensed 10 times consecutively.

STOP key 8 — Use this key to pause the coverslipping operation or cancel the initial priming of mounting medium.

START key 9 — Use this key to start a new coverslipping operation or resume the paused coverslipping operation.

RACK lamp 10 — This lamp illuminates when the unloading door is opened to place or remove receiving racks.

LOAD lamp 11 — This lamp illuminates when the loading station access door is opened to place baskets.

EXIT key 12 — Use this key to cancel the current setting operation without saving the changes and return to the previous screen.

MENU key 13 — Pressing this key displays the menu screen. Press the key twice, and the sub menu screen will appear.

ENTER key 14 — Press this key to accept and save the current setting.

</> keys 15 — Use these keys to select a desired item from a list. Pressing the < key moves the cursor up or to the left, while pressing the > key moves the cursor down or to the right.

Specifications

Models

Model	Name/Description
6500	Tissue-Tek® Glas™ g2 Automated Glass Coverslipper (115 VAC) (USA)
6501	Tissue-Tek® Glas™ g2 Automated Glass Coverslipper (100 VAC) (Asia)
6502	Tissue-Tek® Glas™ g2 Automated Glass Coverslipper (230 VAC) (Europe)

Power Supply Requirements

Model	Power	Frequency	Amps
6500	115 VAC ± 10% @ <15A	50/60 Hz	2.2A
6501	100 VAC + 10%/–5% @ <15A	50/60 Hz	2.5A
6502	230 VAC ± 10% @ < 7A	50/60 Hz	1.2A

Electrical Safety

For Model 6500 –

cETL Certification

- Safety requirements UL61010A-1:2004,
- CAN/CSA-C22.2 No.61010-1:2004

For Model 6501 –

CE Marking

- Safety requirements IEC61010-1:2001
- EMC Directive IEC61326-1:2002
- In-vitro Diagnostic Directive IEC61010-2-101:2002
- Risk management ISO14971:2000

For Model 6502 –

Amendment of Pharmaceutical Affairs Law

- Safety requirements J IS C1010-1:2005
- EMC JIS C1806-1:2001
- Risk management JIS T14971:2003

Dimensions

750 (W) x 620 (D) x 750 (H) mm

Instrument Weight

Approximately 110 kg (242.5 lbs)

Operating Conditions

Operational Temperature: 10°C to 40°C (50°F to 104°F)

Relative Humidity: 30-85% (non-condensing)

Protect from direct sunlight

Capacity

Coverslipping Speed: up to 420 slides/hour

Acceptable Dimensions for Slides

Dimensions:

25.0 to 26.0 (width) x 75.0 to 76.0 (length) mm

Thickness:

0.9 to 1.2 mm

Acceptable Dimensions for Cover Glass

Dimensions:

24 (width) x 40, 50, 55, 60 (length) mm

25 (width) x 40, 50, 55, 60 (length) mm

If 25-mm wide cover glasses are used, the system may have to be readjusted.

Thickness:

0.9 to 1.2 mm

Compatible Solvent

Xylene

D-Limonene-based substitutes

Aliphatic-Hydrocarbon-based substitutes

Compatible Mounting Medium

Xylene-based mounting medium

D-Limonene-based mounting medium

Aliphatic-Hydrocarbon-based mounting medium

INTRODUCTION

INSTALLATION & SETUP

General Information

This section provides detailed installation and setup instructions for the Tissue-Tek® Glas™ *g2* Automated Glass Coverslipper. The installation steps must be followed correctly to ensure proper operation and service. Read this Operating Manual carefully before attempting to operate the instrument. Follow all instructions carefully.

The Tissue-Tek Glas *g2* Coverslipper is a precision instrument and must be handled accordingly. Rough handling or dropping the instrument will disturb or damage internal components. Always handle the instrument with care.

Select a place where sufficient clearance can be provided around the instrument. A clearance of at least 10 cm is required for the top and left side of the instrument. To the right of the instrument, at least 30 cm should be provided.

Environmental Factors

As with all sensitive electronic instruments, prolonged exposure to excessive humidity and temperature should be avoided. Temperature and humidity should be held relatively constant. The ambient temperature range for operating the instrument is 10°C to 40°C (50°F to 104°F). The ambient operating humidity range is 30-85% relative humidity.

Locate the instrument in a well-ventilated area, avoiding exposure to corrosive vapors and extreme variations in temperature or humidity. The area should be clean and dust-free and have a firm, level surface capable of holding at least 110 kg (242.5 lbs.) of weight. Be sure it is near a power source that meets the electrical requirements specified on the rating label located on the rear of this instrument. The power receptacle must be grounded and should be a dedicated line. Avoid proximity to direct sunlight, open windows, sinks, ovens, hot plates, open burners, or radiators.

Unpacking

Before unpacking the Glas *g2* coverslipper, please refer to the detailed instructions in the separate document titled: "Tissue-Tek® Glas™ *g2* Unpacking Procedures" or call the local Sakura sales representative for assistance.

CAUTION: The instrument is very heavy and large; therefore, it is strongly recommended that it always be lifted and transported by at least two people, one positioned on each side.

INSTALLATION & SETUP

Unpacking the Accessories (Figure 2-A)

When opening the accessory box, confirm that all accessories have been included with the instrument:

- 20-Slide basket adapter (10), product code 6138
- 20-Slide baskets (10), product code 4768
- Receiving racks (12), product code 6504
- Power cord (1), product code A40-105-11
- Loading station (1), product code N94-013-00
- Basket receiver, loading station (1), product code N94-014-00
- Lid, loading station (1), product code N94-015-00
- Anti-drying bottle (1), product code 6423
- Waste container (1), product code 6430
- Dispensing tray (1), product code N94-041-00
- Mounting medium bottle tray (1), product code N94-357-00
- Cover glass tray (1), product code N94-041-00
- Slide protect seat (1), product code N94-373-00
- Priming bottle (1), product code 6433
- Waste bottle (1), product code 6505
- Wire brush (1), product code D8-60-0000
- Level (1), product code D9-60-0000
- Activated carbon cartridge (1), product code 6160
- Tissue-Tek® Glas™g2 link system (1 set), product code 6168
- Operating manual (1), product code 0002783-01

Options (Figure 2-B)

- 22 Cover glass holder (250-slide type)
 - 24 x 40 mm (1 piece), product code N94-084-00
 - 24 x 50 mm (1 piece), product code N94-085-00
 - 24 x 55 mm (1 set), product code N94-086-00
 - 24 x 60 mm (1 set), product code N94-087-00
- 23 Exhaust hose set 1, product code 6506
- 24 Exhaust hose set 2, product code 6507

Shipped separately:

- Tissue-Tek® Glas™ Mounting Medium, product code 6419

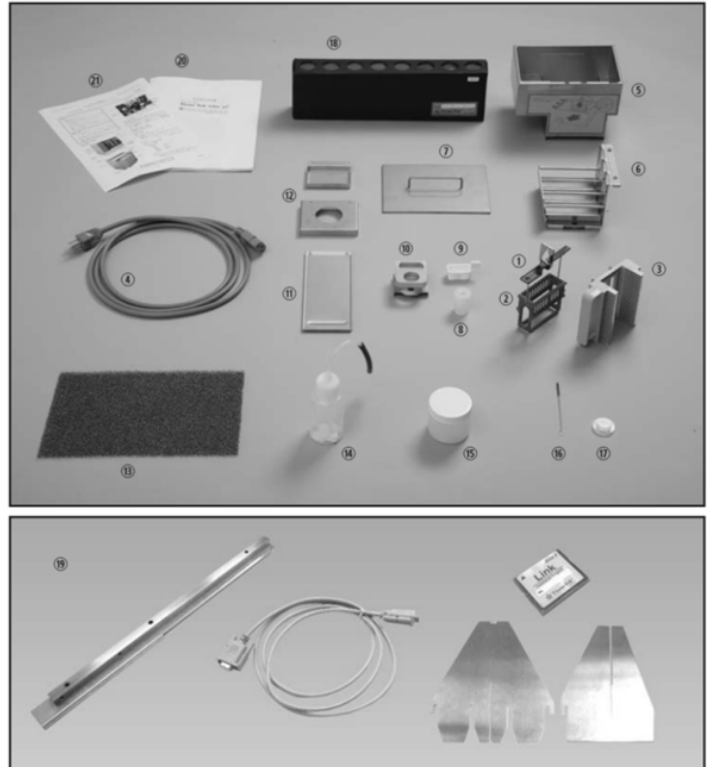

Figure 2-A

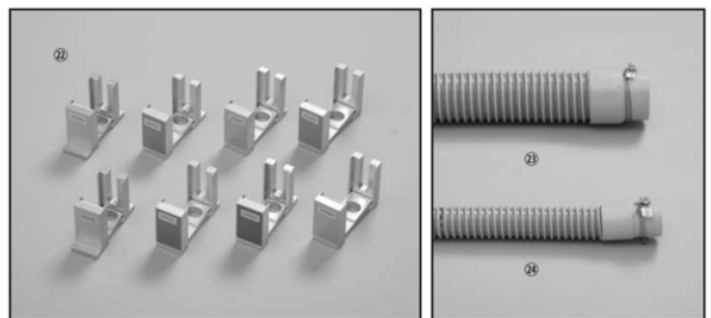

Figure 2-B

Installation of Accessories and Consumable Supplies

Installation of Accessories

This section explains how to install the various accessories.

Using the Basket Adapter (Figures 2-C & 2-D)

1. Align the direction of the "UP SIDE" mark on the top face of the basket adapter with the direction of the "UP SIDE" mark on the side face of the basket.
2. Insert one tip of the basket adapter into a basket adapter hole.
3. While gently pulling the basket adapter wire, insert the other tip into a basket adapter hole.

NOTE: Place the slides in the basket by making sure their tissue slide aligns with the "UP SIDE" direction.

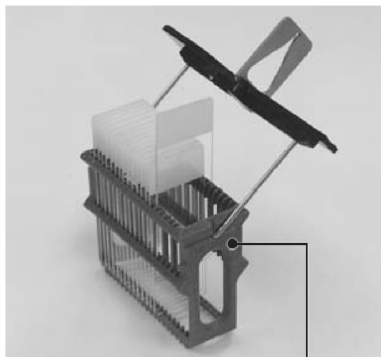

Figure 2-C



Figure 2-D

Installing the Receiving Rack (Figure 2-E)

1. Open the unloading door.
2. Grab the receiving rack (Figure 2-F) handle in such a way that the slide unloading area faces to the right side, and then place the receiving rack in the recessed area of the unloading area (indicated by the shaded box in Figure 2-G). Up to 12 receiving racks can be placed.
3. Close the unloading door.

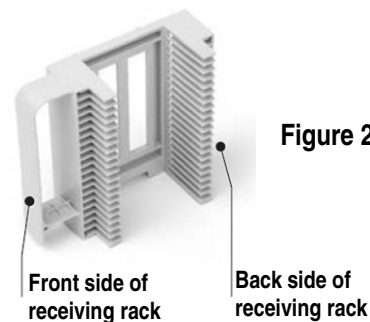

Figure 2-E



Figure 2-F



Figure 2-G

Recessed area where receiving racks are placed

INSTALLATION & SETUP

Installing the Loading Station

1. Align the direction of the basket receiver with the direction of the loading station. Insert the pin inside the loading station into the hole in the basket receiver, then insert the loading station all the way to the end (Figure 2-H & Figure 2-I).

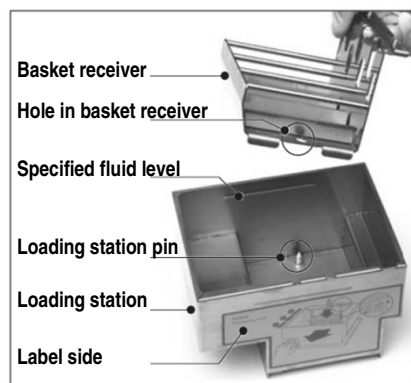

Figure 2-H



Figure 2-I

View of Complete Assembly

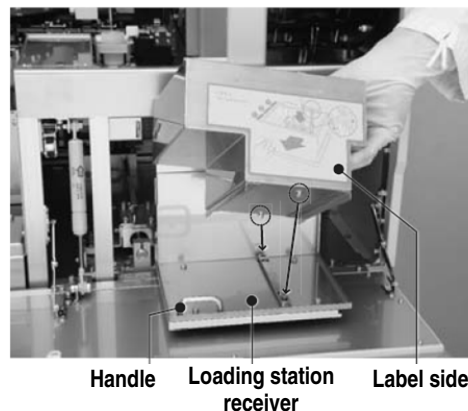

Figure 2-J

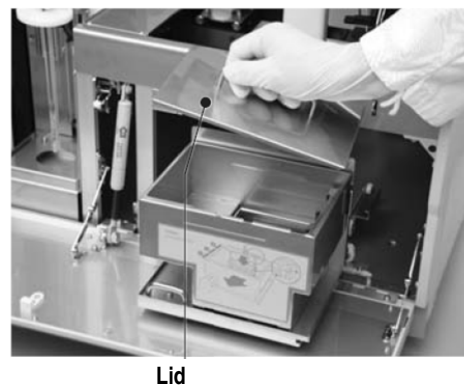

Figure 2-K

CAUTION: If the amount of solvent is insufficient, air bubbles may be introduced and tissues may dry up.

2. Fill with solvent until the specified level (approx. 1.5 liters) is reached.
3. Open the loading station access door, grab the handle, and pull out the loading station receiver.
4. Place the loading station on the loading station receiver by making sure the basket receiver faces the right side (Figure 2-J).
5. Place the dedicated lid on the loading station and push the loading station back into the system (Figure 2-K).
6. Close the loading station access door.

Connecting the Power Cable

1. Turn the power switch to OFF.
2. Connect the power cable to the power inlet on the system (Figure 2-L).
3. Connect the power plug to a power outlet with a grounding terminal (3P).



Power inlet

Figure 2-L

Installing the Mounting Medium Bottle Tray

1. Place the mounting medium bottle tray (A) by aligning it with the pins provided on the inner face of the bottom plate of the mounting medium storage area (Figure 2-M).
2. Place the mounting medium bottle tray (B) by aligning it with the pins provided on the outer face of the bottom of the mounting medium storage area (Figure 2-N).



Mounting medium
bottle tray (A)

Figure 2-M



Mounting medium
bottle tray (B)

Figure 2-N

Installing the Dispensing Tray

1. Turn the power switch to OFF.
2. Open the cover.
3. Place the dispensing tray in the system.
4. Fill solvent in the anti-drying bottle until just below the lid (Figure 2-O). The dispensing nozzle should sit above the fluid level so the solvent vapors prevent the mounting medium at the tip of the dispensing nozzle from solidifying. Be careful not to let the tip of the dispensing nozzle contact the solvent.



Fill solvent until this line just
below the lid.

Figure 2-O

CAUTION: Do not use toluene or any liquid containing toluene. Instrument malfunction or failure may result. Check the amount of solvent for mounting medium, such as xylene, before use. Failure to do so may cause the tip of the dispensing nozzle to stick, resulting in incorrect coverslipping operation and negative consequences on the tissues.

INSTALLATION & SETUP

- Place the anti-drying bottle and waste container in the dispensing tray (Figure 2-P). First, push back the dispensing nozzle in and then place the bottle (Figures 2-Q, 2-R, & 2-S).

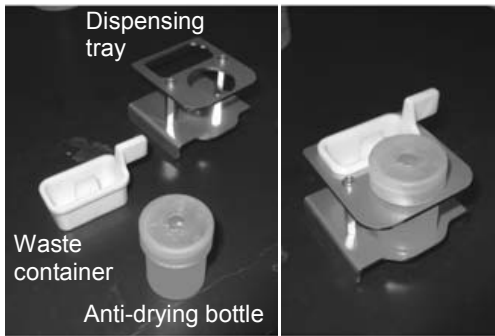

Figure 2-P



Figure 2-S

Waste Container
Anti-drying bottle

- After the anti-drying bottle and waste container have been placed, lift the dispensing nozzle and return the nozzle so that its tip enters the hole in the anti-drying bottle (Figure 2-T).



Figure 2-Q

Dispensing nozzle

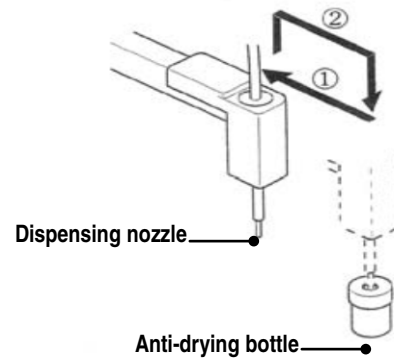

Figure 2-T

Dispensing nozzle
Anti-drying bottle



Figure 2-R

Dispensing tray

Installation of Accessories and Consumable Supplies

This section explains how to install the consumable supplies.

Cover Glass Tray

1. Turn the power switch to OFF.
2. Open the cover.
3. Position the cover glass tray by aligning it with the two pins provided on the side toward the front of the instrument (Figure 2-U & 2-V).

NOTE: In certain situations such as when two cover glasses are picked up together, the cover glass tray prevents the cover glass or glasses that have dropped during the retrieval operation from further dropping into the system.



Figure 2-U



Cover glass tray

Slide Glass Sheet

1. Turn the power switch to OFF.
2. Open the cover.
3. Move the cover glass holder to the right.
4. Lift the receiving rack arm.
5. Place the sheet in the tray below the receiving rack arm (Figure 2-W).

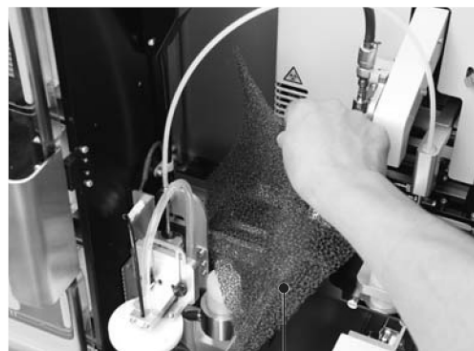

Slide glass sheet

Figure 2-W

Link System

By opening the aperture provided in the right side face of the system (Figure 2-X), it is possible to link the system with the automatic stainer (Tissue-Tek® Prisma™). For details on installing the link system, consult the Sakura dealer.



Figure 2-X

INSTALLATION & SETUP

Exhaust Hose

By opening an adapter to connect an exhaust hose is provided at the back of the system. A hose with a diameter of 38 or 75 mm can be connected.

Options

- Exhaust hose set 1 (38 mm type): 38 mm hose (5 m), hose bands, cuffs (Figure 2-Y)
- Exhaust hose set 2 (75 mm type): 75 mm hose (5 m), hose bands, cuffs (Figure 2-Z)



Exhaust hose set 1



Exhaust hose set 2

Figure 2-Y

Figure 2-Z

Installing the Activated Carbon Filters

1. Press on the front of the fume control door to release the lock, and then pull out the fume control door (Figure 2-AA).
2. Place two new activated carbon cartridges in the activated carbon cartridge storage area. If used activated carbon cartridges are present, remove both cartridges and replace them with new ones.
3. Push back the fume control unit door into the system until it clicks into place.



Figure 2-AA

Exhaust part

Activated carbon cartridge and storage area

Installing the Mounting Medium Bottle

The mounting medium suction tube is equipped with a level detection sensor. Set the tube and sensor correctly.

1. Open the lid of the mounting medium bottle. Use a 500-mL bottle containing mounting medium, such as the Tissue-Tek® Glas™ Mounting Medium, product code 6419.
2. Tilt the mounting medium introduction tube toward the front of the instrument and lift the tube. (Figure 2-BB).
3. Slowly insert the mounting medium introduction tube and level detection sensor into the mounting medium bottle (Figure 2-BB).

CAUTION: If the mounting medium bottle is inserted too quickly, air bubbles may enter the mounting medium. If the system is operated continuously with air bubbles in the mounting medium, air bubbles may be coverslipped together with the tissues.

4. Return the mounting medium introduction tube and level detection sensor to the vertical position, and then lower them to the bottom. If a gap generates between the disk-shaped cap and the bottle, adjust the gap along the mounting medium bottle

CAUTION: When installing mounting medium for the first time or change the type of mounting medium, “initial priming of mounting medium” must be performed. For the procedure to perform this operation, refer to Section 3, “Initial Priming”.

Adjusting the Gap along the Mounting Medium Bottle

1. Loosen the two screws at the cap installation mechanism.
2. Gently push the cap against the mounting medium bottle and while the cap is in contact with the bottle, tighten the two screws that were loosened (Figure 2-CC).

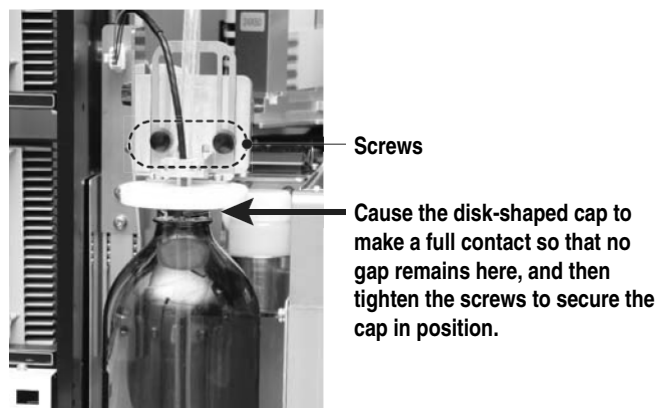

Figure 2-CC

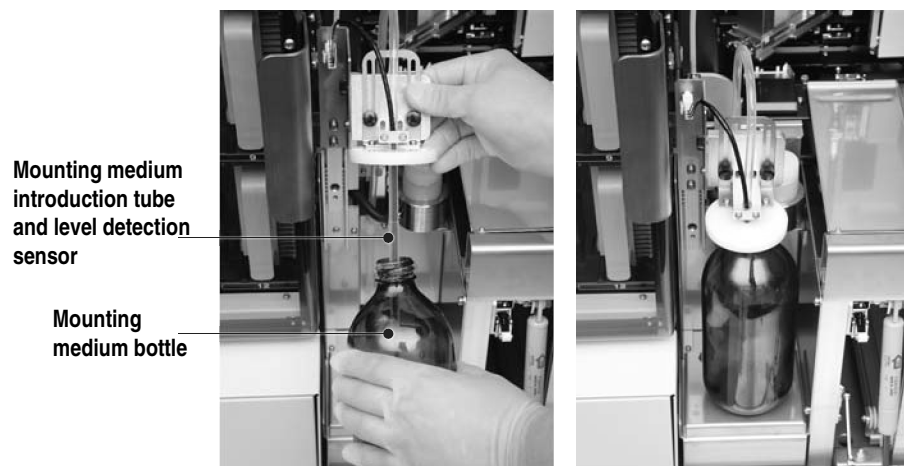

Figure 2-BB

INSTALLATION & SETUP

Placing the Cover Glasses

NOTE: Place commercial holders provided by cover glass manufacturers directly in the system. Dedicated cover glass holders are also provided as options (sold separately). When using dedicated cover glass holders, place cover glasses in the holders (Figure 2-DD).

1. Open the instrument cover.
2. Place the cover glass holder so that the tab of the cover glass holder fits in the holder.
3. Close the instrument cover.

The following eight types of cover glasses can be used:

24 x 40, 24 x 50, 24 x 55, 24 x 60 (mm)

25 x 40, 25 x 50, 25 x 55, 25 x 60 (mm)

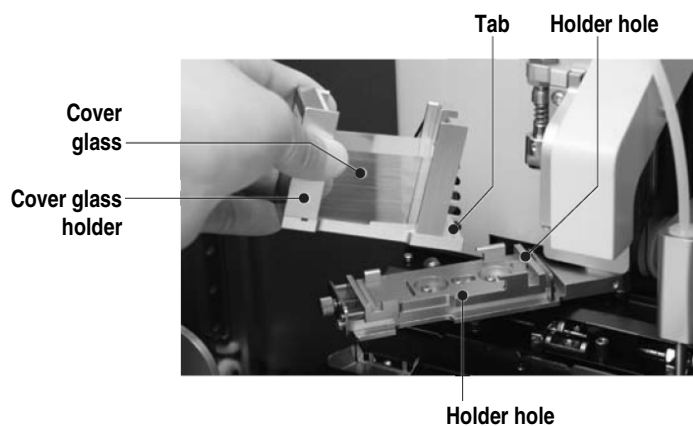

Figure 2-DD

CUSTOMIZATION OF SETTINGS

General Information

This section explains the operations of the main menu screen and how to change each setting.

Explanation of the Main Menu

The menu screen allows selection of various menu items during the initial installation or checking/changing the system settings (Figure 3-A).

Pressing the **MENU** key will bring the menu screen. Press the < and > keys to highlight the desired item, and then press the **ENTER** key to select.

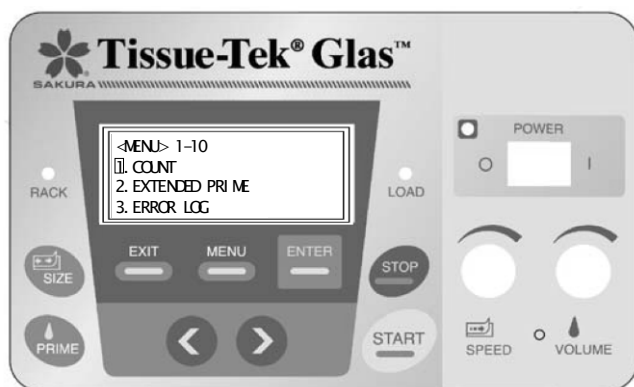

Figure 3-A

Menu Item Descriptions

1. **COUNT**- Indicates the number of slides that have been coverslipped. The counter can be reset. See page 3.2.
2. **EXTENDED PRIME**- Mounting medium is dispensed continuously from the tip of the nozzle. Select this menu item when loading mounting medium for the first time, changing the mounting medium, or when air bubbles have entered the tubing. See page 3.3.
3. **ERROR LOG**- Provides a log of errors that have occurred. See page 3.4.
4. **PROGRAM EDIT**- Sets the names and details of coverslipping programs that specify coverslipping conditions. Up to nine coverslipping programs can be stored in memory, each specifying a different cover glass size, coverslipping speed, and volume of mounting medium. See page 3.4.
5. **PROGRAM LOCK**- Prevents program changes during coverslipping. Select “Lock” or “Unlock.” Real-time change of coverslipping speed and volume of mounting medium is enabled only when “Unlock” is selected. See page 3.5.
6. **KEY SOUND**- Selects whether or not to output a sound when a key is pressed. See page 3.5.
7. **END SOUND**- Changes the sound indicating the completion of coverslipping. Select a desired sound from three pattern choices. See page 3.5.
8. **ALARM**- Selects a desired sound, from four pattern choices, to indicate an error condition. See page 3.6.
9. **START METHOD**- Selects from two start methods: The Start Key method required pressing the start key to initiate coverslipping while the Unloading Station Access Door method will initiate coverslipping as soon as that door is closed. See page 3.6.
10. **CLEANING**- Cleans the interior of the mounting medium tubing using xylene or flushes out the mounting medium left in the tube. The operation is the same as what is performed when “EXTENDED PRIME” is selected. Under “CLEANING,” however, reagent flow is at a higher speed. Do not perform this operation for the purpose of initial priming of mounting medium, because air bubbles will form. See page 3.7.
11. **SOFTWARE VERSION**- Displays the software version. See page 3.7.

CUSTOMIZATION OF SETTINGS

Viewing/Changing the Count

How to view/change the number of slides that have been coverslipped is explained (Figure 3-B).

NOTE: This menu item is available only when the system is on standby or paused, or when the system check screen is displayed.

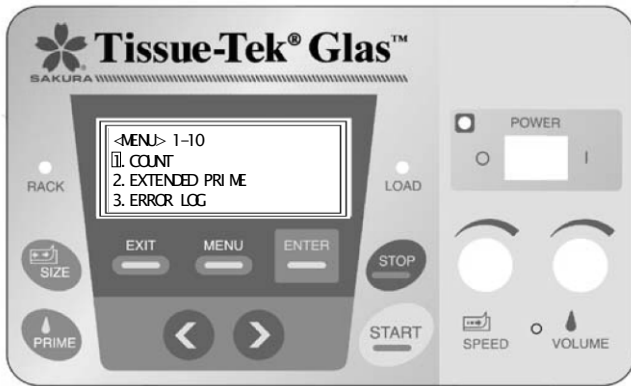

Figure 3-B

1. Press the **MENU** key.
2. Press the < and > keys to highlight 1, “COUNT,” and then press the **ENTER** key and the counter screen appears (Figure 3-C).
3. Press the **STOP** key. The COUNT clear confirmation screen appears (Figure 3-D).

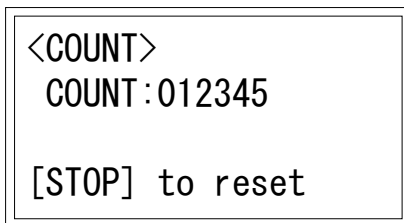

Figure 3-C: Counter Screen

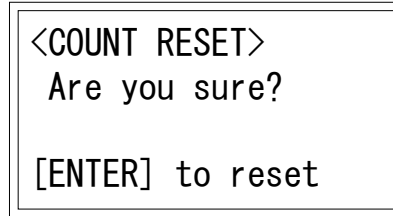

Figure 3-D: Counter Reset Confirmation Screen

The count is indicated as a 6-digit number and when the count reaches “999999,” it will return to “1.” The count increments every time a slide is coverslipped.

To manually increase or decrease the count press the < or > key.

Initial Priming

When installing the mounting medium bottle for the first time or when introducing a new type of mounting medium, the dispense tubing must be flushed out. A series of operations performed for these purposes is called “initial priming.”

In initial priming, mounting medium is pulled out continuously from the mounting medium bottle and dispensed continuously from the tip of the dispensing nozzle.

To install mounting medium for the first time or change the type of mounting medium, also refer to “Installing/Replacing the Mounting Medium Bottle.”

NOTE: This menu item is available only when the system is on standby or paused or when the system check screen is displayed.

1. Press the **MENU** key.
2. Press the < and > keys to highlight 2, “EXTENDED PRIME,” and then press the **ENTER** key (Figure 3-E).
3. The extended prime screen appears (Figure 3-F)
4. Open the loading station access door.
5. Open the cover and take out the entire dispensing tray from the system. Remove the entire dispensing tray and set the waste tray for initial priming at a position below the dispensing nozzle.
6. Remove the lid of the waste bottle, and while lifting the dispensing nozzle, place the anti-drying bottle below the dispensing nozzle (on the two guide rails).
7. Fill the priming bottle with solvent (normally xylene), then insert the tip of the tube into the introduction tube (Figure 3-G). Squeeze bottle to introduce solvent into dispensing channel. Fill channel until solvent drips out of the dispensing nozzle.
8. When initial prime has been completed, usually all of the solvent has been removed from the dispensing channel and mounting medium has been introduced. If not, run initial prime one more time.

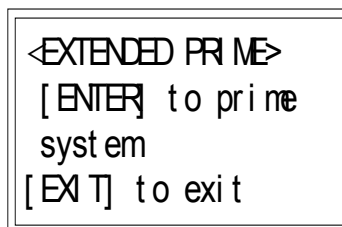

Figure 3-E: Initial Priming Screen

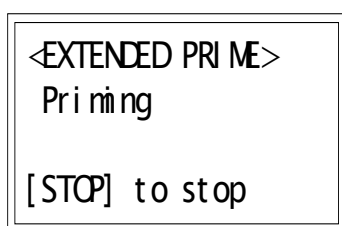

Figure 3-F: Screen during Dispenses

CAUTION: If the system has not been used for an extended period of time, the solvent may not be dispensed evenly when this operation is performed. In this case, the solvent must be forcibly introduced to the priming tubing using a pump bottle for initial priming. For details, contact the Sakura Customer Service Center the Sakura local distributor.

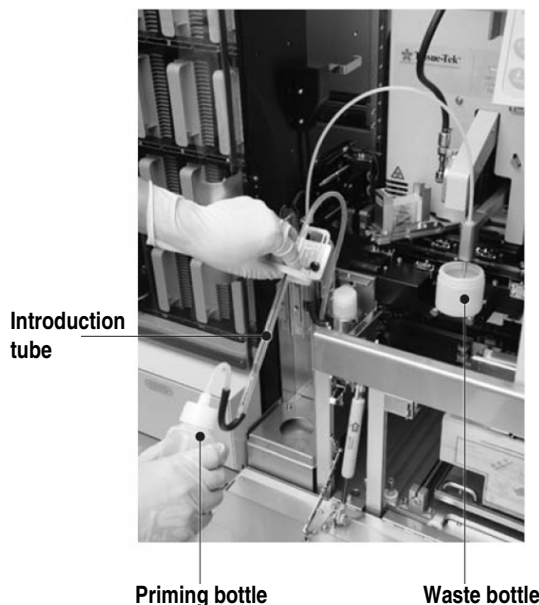

Figure 3-G

CUSTOMIZATION OF SETTINGS

Viewing the Error Log

Up to 99 errors can be displayed, with the newest number representing the latest error.

When more than 99 errors have occurred, the oldest error will be deleted and the latest error will be added.

The displayed items are line number, error number, and count (system slide count).

NOTE: When the power is turned off, error code "99" is automatically registered in the error log.

NOTE: This menu item is available only when the system is on standby or paused or when the system check screen is displayed.

1. Press the **MENU** key.
2. Press the < and > keys to highlight 3, "ERROR LOG," and then press the **ENTER** key.
3. The error log screen appears (Figure 3-H).
4. Pressing the **STOP** key opens the error log clear confirmation screen (Figure 3-I).
5. Press the **ENTER** key to clear the error log. To return to the menu screen without clearing the error log, press the **EXIT** key.

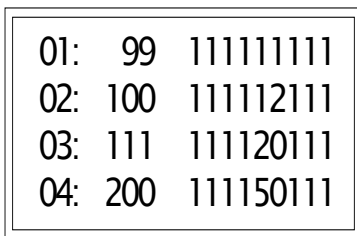

Figure 3-H: Error log Screen

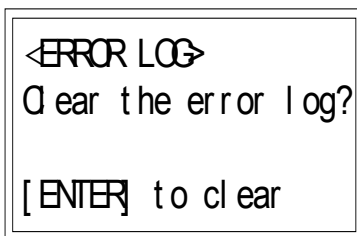

Figure 3-I: Error Log Clear Screen

Creating a Program

A program consists of three items, namely CG (cover glass) size, volume of mounting medium, and coverslipping speed. A program name can also be assigned.

NOTE: This menu item is available only when the system is on standby or paused or when the system check screen is displayed.

1. Press the **MENU** key.
2. Press the < and > keys to highlight 4, "@PROGRAM CREATION@," and then press the **ENTER** key.
3. The program name setting screen appears (Figure 3-I).

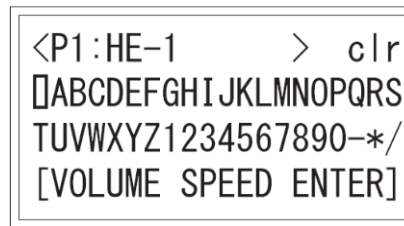

Figure 3-I: Program Name Setting

4. If no name is set, the field is blank. Enter a desired name consisting of up to eight characters.
 - <, > Use these keys to change the program number, from P1 to P9.
 - SPEED This key moves the cursor inside the name field. This field is surrounded by two brackets.
 - VOLUME This key moves the cursor to highlight the desired characters.
 - ENTER Use this key to select and display in the name field the character highlighted using the **VOLUME** key.
 - SIZE Use this key to switch between upper case and lower case characters.
 - EXIT Press this key to return to the menu screen.

- When the **MENU** key is pressed once again, the program edit screen appears (Figure 3-J).

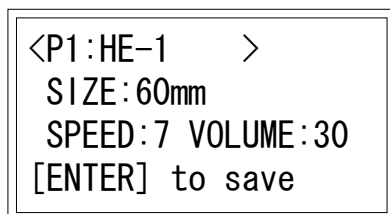

Figure 3-J: Program Edit Screen

- Set the cover glass size, coverslipping speed and volume of mounting medium for each program.
- Press the **ENTER** key to save the new settings.

Program Lock

Access to program editing can be locked during coverslipping.

NOTE: This menu item is available only when the system is on standby or paused or when the system check screen is displayed.

- Press the **MENU** key.
- Press the < and > keys to highlight 5, “PROGRAM LOCK,” and then press the **ENTER** key.
- The Lock/Unlock screen appears (Figure 3-K).
- Press the < and > keys to select **Lock** or **Unlock**.
- Press the **ENTER** key to save the new settings.

NOTE: When Lock is selected, the coverslipping speed and volume of mounting medium can no longer be changed in real time during coverslipping.

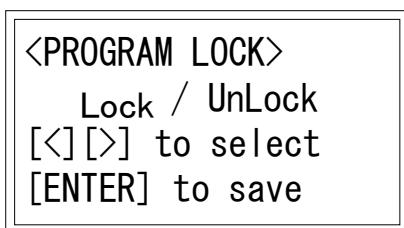

Figure 3-K: Lock/Unlock Selection Screen

Selecting the Key Sound

This function allows the key sound to be turned on/off.

NOTE: This menu item is available only when the system is on standby or paused or when the system check screen is displayed.

- Press the **MENU** key.
- Press the < and > keys to highlight 6, “KEY SOUND,” and then press the **ENTER** key.
- The key sound screen appears (Figure 3-L).
- Press the < and > keys to select **OFF** or **ON**.
- Press the **ENTER** key to save the selected setting. To return to the menu screen without saving the change, press the **EXIT** key.

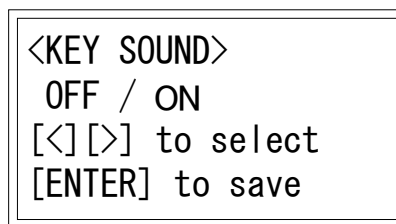

Figure 3-L: Key Sound Setting Screen

Selecting the Coverslipping End Sound

To indicate end of coverslipping there is a choice of three different sound patterns.

NOTE: This menu item is available only when the system is on standby or paused or when the system check screen is displayed.

- Press the **MENU** key.
- Press the < and > keys to highlight 7, “END SOUND,” and then press the **ENTER** key.
- The end sound setting screen appears (Figure 3-M).

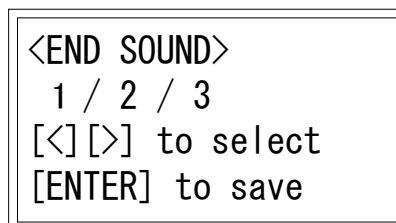

Figure 3-M: End Sound Setting Screen

CUSTOMIZATION OF SETTINGS

4. Press the < and > keys to select a desired option from 1, 2, and 3.
 - Pattern 1 A short “beep” sound is output six times repeatedly.
 - Pattern 2 An intermediate length “beep” sound is output six times repeatedly.
 - Pattern 3 A long “beep” sound is output six times repeatedly.
5. Press the **ENTER** key to save the selected setting. To return to the menu screen without saving the change, press the **EXIT** key.

Selecting the Alarm Volume/Tone

This sets a desired volume and tone for both the alarm sound and the end sound. There are four pattern choices.

NOTE: This menu item is available only when the system is on standby or paused or when the system check screen is displayed.

1. Press the MENU key.
2. Press the < and > keys to highlight 8, “ALARM,” and then press the ENTER key.
3. The alarm setting screen appears.
4. Press the < and > keys to select a desired option from 1, 2, 3 and 4 (Figure 3-N).





Pattern	Volume	Tone
1	 Small	Low pitch
2	 Medium	Low pitch
3	 Large	High pitch
4	 Very Large	High pitch

Figure 3-N

5. Press the **ENTER** key to save the selected setting. To return to the menu screen without saving the change, press the **EXIT** key (Figure 3-O).

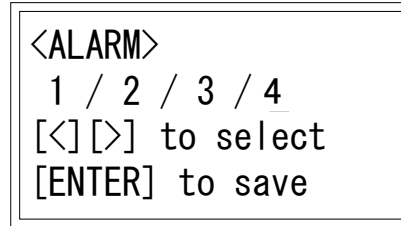

Figure 3-O: Alarm setting Screen

Selecting the Start Method

Select between two start methods using this function.

NOTE: This menu item is available only when the system is on standby or paused or when the system check screen is displayed.

1. Press the MENU key.
2. Press the < and > keys to highlight 9, “START METHOD,” and then press the ENTER key.
3. The start method setting screen appears (Figure 3-P).
4. Press the < and > keys to select either “START KEY” or “UNLOADING STATION ACCESS DOOR.”
 - “START KEY” Operation will start when the START key is pressed.
 - “UNLOADING STATION ACCESS DOOR” Operation will start when the unloading station access door is closed.
5. Press the **ENTER** key to save the selected setting. To return to the menu screen without saving the change, press the **EXIT** key.

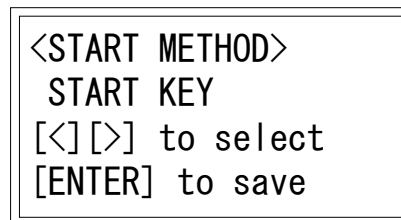

Figure 3-P: Start Method Setting Screen

Cleaning the Interior of the Mounting Medium Tubing

The purpose of this procedure is to clean the interior of the mounting medium tubing using a solvent, preferably xylene. Do not use this cleaning function to prime the mounting medium as the flow rate is too high and will generate air bubbles in the line

CAUTION: In this mode, the dispensing pump is operated at the maximum stroke just like during initial priming. Suction and dispense operations are performed. Also, do not use this mode for initial priming of mounting medium because air bubbles will generate as mounting medium is introduced.

NOTE: This menu item is available only when the system is on standby or paused or when the system check screen is displayed.

1. Press the **MENU** key.
2. Press the < and > keys to highlight 10, "CLEANING," and then press the **ENTER** key.
3. The cleaning screen appears (Figure 3-Q).
4. Place a full bottle containing solvent.
5. Remove the entire dispensing tray from the system and set the waste tray for initial priming at a position below the dispensing nozzle.
6. Press the **START** key to start cleaning.
7. To cancel dispensing of solvent, press the **STOP** key (Figure 3-R). Once the dispensing stops, the display returns to the menu screen.
8. Remove the waste tray for initial priming and set the original dispensing tray again.
9. To return to the menu screen, press the **EXIT** key.

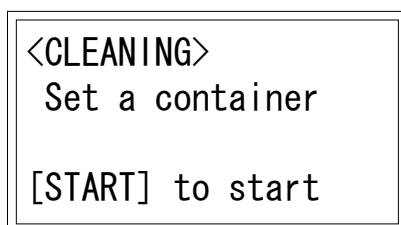

Figure 3-Q: Cleaning Screen

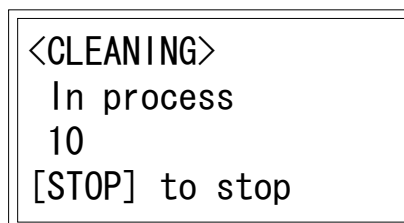

Figure 3-R: Cleaning in Progress Screen

Viewing the Software Version

View the software version using this function.

NOTE: This menu item is available only when the system is on standby or paused or when the system check screen is displayed.

1. Press the **MENU** key.
2. Press the < and > keys to highlight 11, "SOFTWARE VERSION," and then press the **ENTER** key.
3. The software version screen appears (Figure 3-S).
4. To return to the menu screen, press the **EXIT** key.

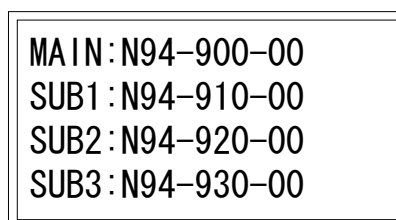

Figure 3-S: Software Version Screen

CUSTOMIZATION OF SETTINGS

Explanation of Sub Menu Items

This section explains the operations available from the sub menu screen and how to change each setting (Figure 3-T).

When the **MENU** key is pressed, the menu screen appears. When the **MENU** key is pressed again, the display switches to the sub menu screen.

The coverslipping performance of this system changes according to the various conditions such as the thickness of glass slide, whether or not the slide is coated, characteristics of mounting medium, tissue type, and temperature/humidity. So that coverslipping is performed properly, the set values of coverslipping conditions used by the system must be changed according to each situation.

The sub menu provides an adjustment menu for achieving optimal coverslipping when the present condition of coverslipping is not favorable.

Press the **MENU** key to open then menu screen, and then press the **MENU** key again to move to the sub menu screen.

Highlight a desired item using the < and > keys, and make the selection using the **ENTER** key.



Figure 3-T

1. **SLOWDOWN POSITION**- This function changes the pressure applied when the cover glass is placed on the slide. Use this menu item mainly when air bubbles are present or mounting medium is seeping out around the slide. See page 3.9.
2. **COVER GLASS ANGLE**- This function changes the separation angle when a cover glass is picked up. Use this menu item when more than one cover glass is picked up or when cover glasses present cracks. Select one of three values. If the cover glass brand is changed, the value may need to be changed. See page 3.10.
3. **PICK UP SPEED**- This function changes the speed at which the glass slide is picked up. When the glass slide pickup speed is changed, the amount of xylene remaining on the slide at the time of pickup will change. Use this menu item mainly when air bubbles are present or mounting medium is seeping out from the slides. If the solvent type is changed, this value may need to be changed. See page 3.11.
4. **DISPENSE POINT**- This function changes the position at which to start dispensing mounting medium onto the glass slide, in a front to back direction. Use this menu item mainly when air bubbles are present on the front side of the slide or mounting medium is seeping out from the sides. See page 3.12.
5. **FIRST DISPENSE**- This function adjusts the volume of mounting medium to be dispensed at the dispense point. The default value is 20 μ L. Use this menu item mainly when air bubbles are present on the front side of the slide or mounting medium is seeping out from the sides. See page 3.13.
6. **DRYING FAN TIMER**- This function changes the receiving racks drying time in the unloading area after completion of coverslipping. End of drying will be signaled by an audible alarm. The default is 2 minutes. See page 3.13.

Setting the Slowdown Position

To change the pressure applied to the cover glass during coverslipping, use this function (Figure 3-U).

NOTE: This menu item is available only when the system is on standby or paused or when the system check screen is displayed.

Quality coverslipping can be achieved by pressing on the cover glass with appropriate force. If air bubbles are present or mounting medium seeps out from the sides, take the following actions:

- If air bubbles are present, raise the slowdown position (increase the pressure).
- If mounting medium seeps out from the sides, lower the slowdown position (decrease the pressure).

1. Press the **MENU** key twice.
2. Press the < and > keys to highlight 1, "Slowdown position," and then press the **ENTER** key. The slowdown position setting screen appears (Figure 3-V).
3. Pressing the < key decreases the value, while pressing the > key increases the value.
4. Press the **ENTER** key to save the selected setting. To return to the menu screen without saving the change, press the **EXIT** key.



Figure 3-U

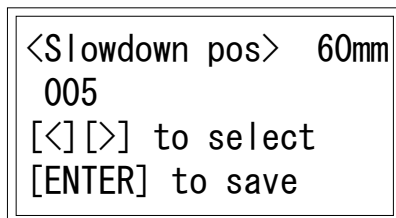

Figure 3-V: Slowdown Position Setting Screen

CUSTOMIZATION OF SETTINGS

Setting the Cover Glass Angle

Use this function to select a desired angle at which to pick up the cover glasses.

NOTE: This menu item is available only when the system is on standby or paused or when the system check screen is displayed.

The coverslipping arm operates at an angle when picking up cover glasses.

This angle is called the “cover glass angle.”

Each cover glass varies depending on its brand and the storage environment. If the cover glass angle is not appropriate for the specific type of cover glass, cover glasses may crack when picked up or more than one cover glass may be picked up together. When this occurs, take the following actions:

- If two cover glasses are often picked up together, increase the cover glass angle.
- If cover glasses often crack, reduce the cover glass angle.

1. Press the **MENU** key twice.
2. Press the < and > keys to highlight 2, “Cover Glass Type,” and then press the **ENTER** key.
3. The cover glass angle setting screen appears (Figure 3-W).
4. Press the **SIZE** key and select the cover glass size for which the angle is to be changed.
5. Press the < and > keys to change the cover glass angle for each size.
6. Press the **ENTER** key to save the selected setting. To return to the menu screen without saving the change, press the **EXIT** key.

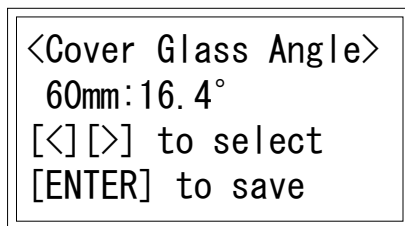

Figure 3-W: Cover Glass Angle Setting Screen

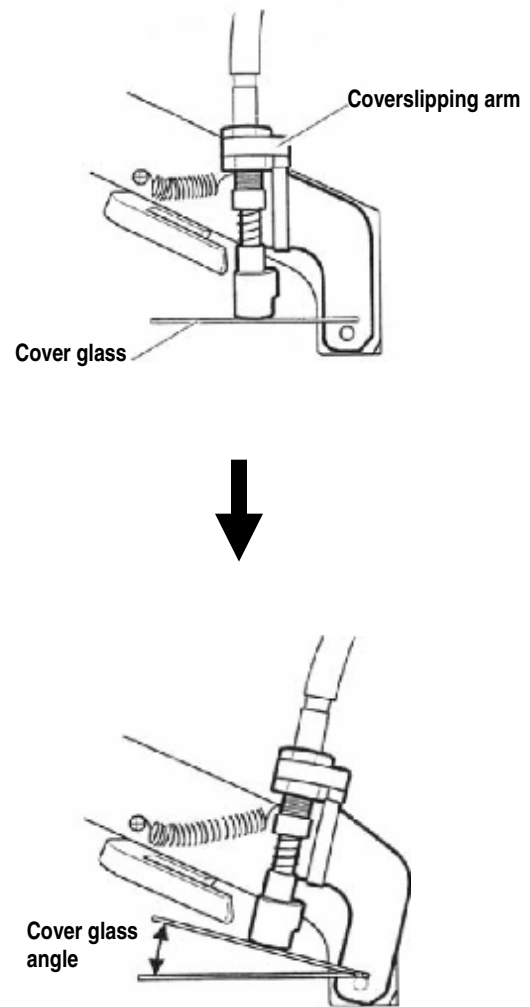

Figure 3-X

Setting the Slide Pickup Speed

Use this function to select a desired speed at which to pick up the slide.

NOTE: This menu item is available only when the system is on standby or paused or when the system check screen is displayed.

The pickup speed setting must be changed according to the water repellency of glass slide and viscosity of mounting medium. The amount of solvent remaining on the slide can be controlled by changing the pickup speed (Figure 3-Z).

NOTE: As the pickup speed decreases the amount of solvent remaining on the slide decreases.

NOTE: As the viscosity of mounting medium increases the amount of solvent remaining on the slide increases.

If the amount of solvent on the glass slide is not enough during coverslipping and mounting medium does not spread sufficiently, increase the pickup speed. If the amount of solvent on the glass slide is excessive during coverslipping and mounting medium runs or seeps out around the slide, decrease the pickup speed.

NOTE: In general, xylene substitutes have a slower rate of volatilization than xylene and thus tend to cause mounting medium to run or seep out around the slide. Accordingly, when using a xylene substitute, the slide pickup speed usually needs to be reduced.

1. Press the **MENU** key twice.
2. Press the < and > keys to highlight 3, "Pick up speed," and then press the **ENTER** key.
3. The pick up speed setting screen appears (Figure 3-Y).
4. Press the < and > keys to select a desired option from 1, 2, 3, 4 and 5. The smaller the value, the lower the SG slide pickup speed becomes and the amount of solvent attaching to the glass slide decreases. The greater the value, the higher the SG slide pickup speed becomes and the amount of solvent attaching to the glass slide increases.
5. Press the **ENTER** key to save the selected setting. To return to the menu screen without saving the change, press the **EXIT** key.

```
<Pick-up speed>
 1 / 2 / 3 / 4 / 5
[<] [>] to select
[ENTER] to save
```

Figure 3-Y: Slide Pickup Speed Setting Screen

Mounting Medium and Slide Pickup Speed

Applicable mounting medium	Slide Pickup Speed
Xylene Substitute	Speed 1
Low-viscosity mounting medium	Speed 2
(Default)	Speed 3
High-viscosity mounting medium 1	Speed 4
High-viscosity mounting medium 2	Speed 5

Figure 3-Z

CUSTOMIZATION OF SETTINGS

Setting the Dispense Point

To select the initial position at which to start dispensing mounting medium onto the glass slide, use this function. The setting should be changed under certain conditions such as when air bubbles are present on the front end of the side of the slide or mounting medium seeps out, especially at the front end of the slide (Figure 3-AA).

An optimum point can be set for each size of cover glass.

NOTE: This menu item is available only when the system is on standby or paused or when the system check screen is displayed.

- If air bubbles enter on the front side of the slide, move the point toward the front end of the slide.
- If mounting medium seeps out on the front side of the slide, move the point towards the end of the slide.

1. Press the **MENU** key twice.
2. Press the < and > keys to highlight 4, "Dispense point," and then press the **ENTER** key.
3. The dispense start point setting screen appears (Figure 3-BB).
4. Pressing the < key moves the dispense point towards the front end of the slide, while pressing the > key moves the dispense point towards the back end of the slide.

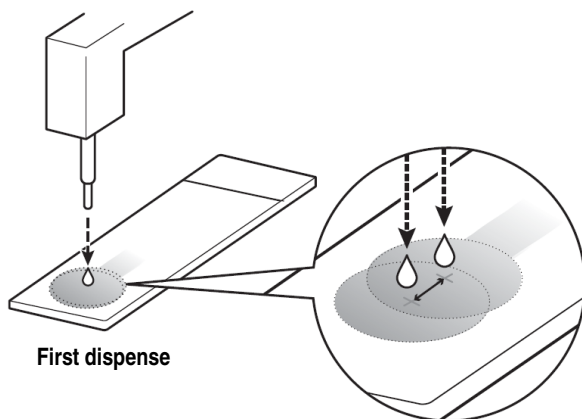

Figure 3-AA

5. Press the **ENTER** key to save the selected setting (Figure 3-CC). To return to the menu screen without saving the change, press the **EXIT** key.

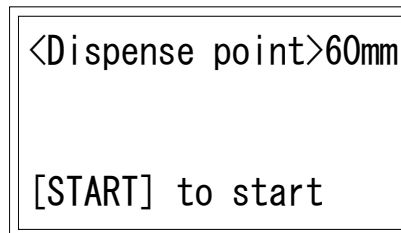

Figure 3-BB: Dispense Point Setting Screen

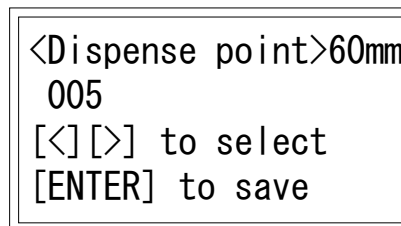

Figure 3-CC: Dispense Point Selection Screen

Setting the First Dispense Volume

During coverslipping, mounting medium is dispensed twice. For the first dispense action, the nozzle remains stationary and mounting medium is dispensed at the current position. For the second dispense action, mounting medium is dispensed as the nozzle moves (Figure 3-DD).

This can change the first dispensing volume of mounting medium using this first dispense volume setting.

NOTE: This menu item is available only when the system is on standby or paused or when the system check screen is displayed.

- If air bubbles enter on the front side (counter-frost side), increase the first dispense volume.
 - If mounting medium drips at a forward position, decrease the first dispense volume.
1. Press the **MENU** key twice.
 2. Press the < and > keys to highlight 5, “First dispense,” and then press the **ENTER** key.
 3. The first dispense volume setting screen appears (Figure 3-EE).
 4. Pressing the < key decreases the value, while pressing the > key increases the value.
 5. Press the **ENTER** key to save the selected setting. To return to the menu screen without saving the change, press the **EXIT** key.

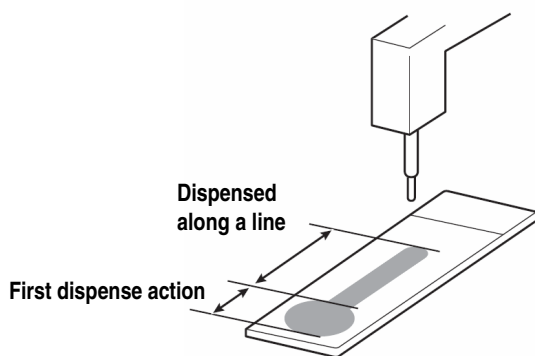

Figure 3-DD

```
<First Dispense>
Offset:0
[<] [>] to select
[ENTER] to save
```

Figure 3-EE: First Dispense Volume Setting Screen

Setting the Slide Drying Time

It is possible to program the amount of time slides dry in the unloading area.

So that the cover glass pasting positions will not shift when the receiving racks containing coverslipped slides are removed, a desired wait time can be set in 30-second increments over a range of 0 to 10 minutes to dry the slides in the unloading area. When drying is completed, a buzzer will sound to notify the completion of drying.

NOTE: This menu item is available only when the system is on standby or paused or when the system check screen is displayed.

1. Press the **MENU** key twice.
2. Press the < and > keys to highlight 6, “Drying Fan Timer,” and then press the **ENTER** key.
3. The drying fan timer setting screen appears (Figure 3-FF).
4. Pressing the < key decreases the value, while pressing the > key increases the value.
5. Press the **ENTER** key to save the selected setting. To return to the menu screen without saving the change, press the **EXIT** key.

```
<Drying Fan Timer>
2min. 30sec.
[<] [>] to select
[ENTER] to save
```

Figure 3-FF: Slide Drying Fan Timer Setting Screen

CUSTOMIZATION OF SETTINGS

OPERATING INSTRUCTIONS

Operating Instructions

This section explains the sequence of operating procedures. The basic flow of operation is shown in the chart below.

Flow of Coverslipping Operation Chart

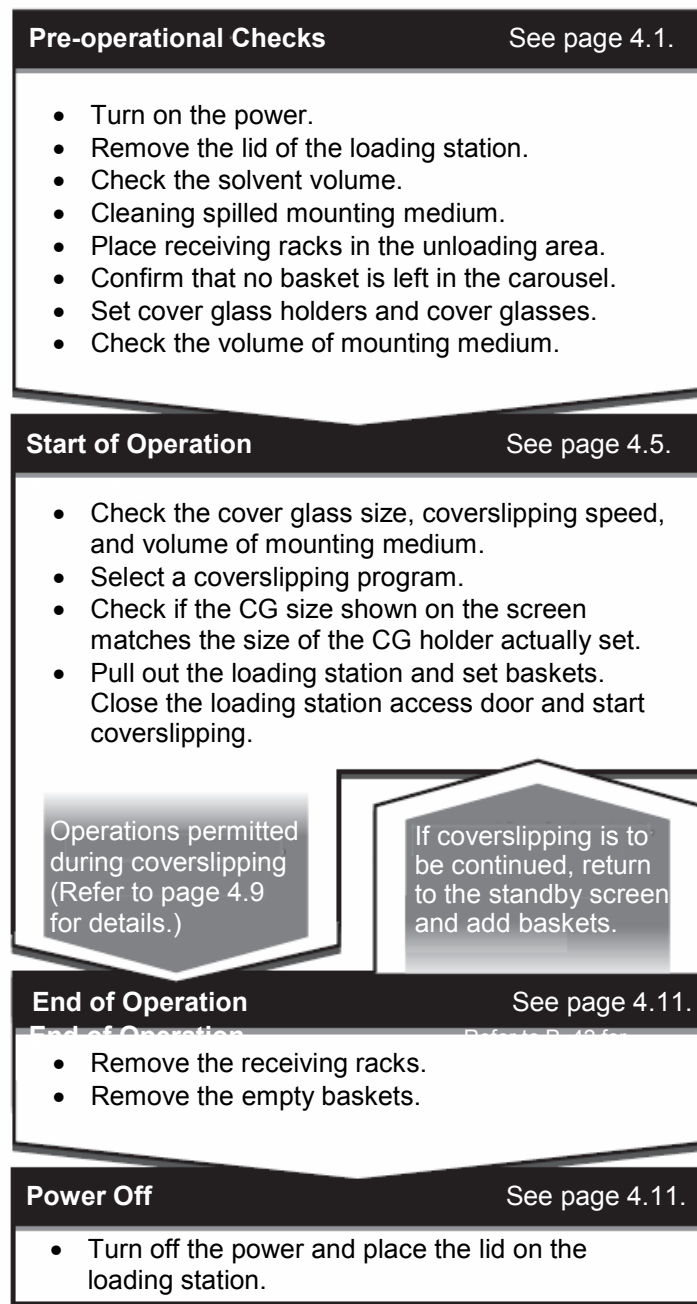

Pre-Operational Checks

This section explains the required steps before operation.

Turning On the Power

1. Press the power switch on the control panel to turn on the power. If the power does not turn on, check if the power cable is connected to the power outlet.
2. Once the power has been turned on, the initial screen is displayed for approximately 5 seconds and then switches to the system check screen. The following prompts are displayed on the screen:
 - Are there sufficient cover glasses? If not, add cover glasses.
 - Is the volume of mounting medium sufficient? If not, change the mounting medium bottle.
 - Are there any slides remaining on transfer arm? Remove the remaining slides, if any.
3. Add/change respective items as necessary. When all items have been reviewed, press the ENTER key to initialize instrument into the home position.
4. When Enter is pressed, the home positioning screen appears. Pressing stop during home positioning procedure will stop the homing process. However, the instrument needs to be in home position to start coverslipping.
5. When the home positioning is completed, the display switches to standby mode.

OPERATING INSTRUCTIONS

Checking the Solvent Volume

If the solvent volume in the loading station, anti-drying bottle, or dispensing pump reservoir is at or below the specified level, add solvent.

■ Loading station (Figure 4-A)

The loading station can accommodate approximately 1.5 L of solvent (use of xylene is recommended). The upper and lower levels are marked inside the loading station, so add solvent to a level between these marks.

NOTE: To prevent contamination, filter or change the solvent in the loading station daily.



Figure 4-A

■ Anti-drying bottle (Figure 4-B)

Add solvent to the lower limit mark just below the lid just covering the bottle.

CAUTION: If solvent runs out, the mounting medium at the tip of the dispensing nozzle may solidify and cause closing. If the mounting medium at the tip of the dispensing nozzle solidifies, coverslipping may not be performed and the tissues may sustain significant damage. Solidified mounting medium at the tip of the dispensing nozzle can also cause the system to fail. Accordingly, confirm that solvent has been added to the specified position.



Figure 4-B

■ Dispensing pump reservoir (Figure 4-C)

Remove the lid and add solvent for mounting medium to the shoulder of the dispensing pump reservoir.

CAUTION: If solvent runs out, the pump that feeds the mounting medium may clog up and become defective. If the pump clogs up, coverslipping may not be performed and the tissues may sustain significant damage. Accordingly, confirm that solvent has been added to the specified position.

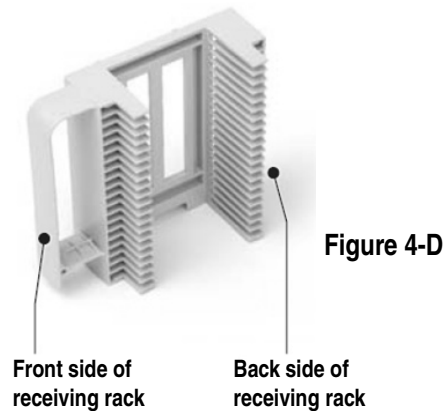

Figure 4-C

Cleaning Spilled Mounting Medium

If mounting medium remains attached to the waste containers and receiving racks, coverslipping may be affected. Before coverslipping is started, clean the waste containers and receiving racks or replace them with clean ones.

CAUTION: If mounting medium remains attached to the waste container (spatula part) or receiving rack, the subsequent coverslipping process may be affected.



Placing Empty Receiving Racks in the Unloading Area

Up to 12 receiving racks can be placed in the unloading area (Figure 4-D).

1. Hold each receiving rack so that the slide unloading area faces the right side (Figure 4-E).
2. A step is provided on the front side of the unloading area, and there is a recessed area in which each rack fits. Place the receiving rack in this recessed area (Figure 4-F). Take note that if the rack is set on the front side of the recessed area or above the step, the system sensor will not detect the rack and this position will not be used.

CAUTION: If the receiving racks placed in the unloading area have no empty slots, the process will stop. Be sure to place empty receiving racks.

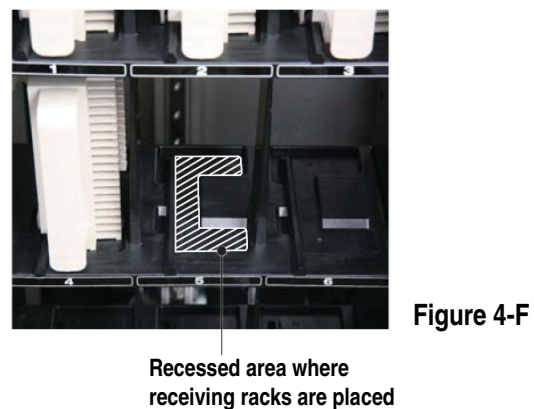

OPERATING INSTRUCTIONS

Removal of Baskets in the Carousel

After all glass slides have moved to the coverslipping station, the empty baskets will be stored in the carousel. If the carousel has no empty slots, coverslipping will not start. Remove all baskets.

Checking the Cover Glass Size

Check the displayed information of the cover glass holder and cover glass box used for coverslipping.

The cover glass holder is available in four sizes of 40, 50, 55, and 60 mm, and a label indicating the applicable size is attached to each holder. Select an appropriate holder according to the length of the cover glass used. Up to 250 cover glasses can be placed in each cover glass holder.

Set the cover glass holder containing cover glasses by orienting the holder in such a way that the side bearing the dimension label faces the front side and the tab of the cover glass holder fits into the holder hole (Figure 4-G).

Checking the Volume of Mounting Medium

Check the volume of mounting medium in the mounting medium bottle. If the level is low, change the bottle with a new mounting medium bottle.

Raise the handle and place a mounting medium bottle (500 mL) underneath. For best results use the Tissue-Tek® Glas™ Mounting Medium, product code 6419.

When changing the mounting medium bottle, complete the operation as quickly as possible because air bubbles will enter the tubing if the handle remains raised for an extended period of time.

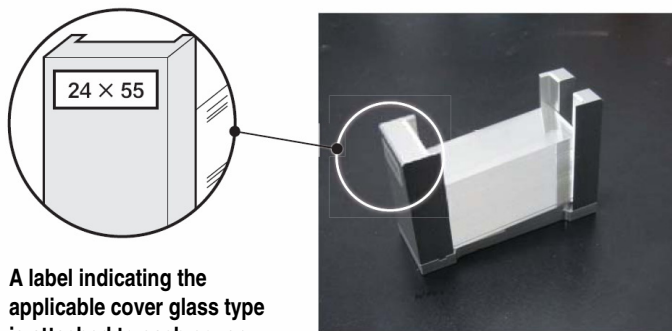

A label indicating the applicable cover glass type is attached to each cover glass holder.

Figure 4-G

Routine Operations

Start of Operation

This section explains the start of operation.

Before instrument operation begins, the following settings must be checked.

Selecting the Program to Be Used

Select the program suitable for the tissues to be coverslipped. Every time the < or > key is pressed, the program number changes to display the registered programs one by one.

To change the program parameter, press the **MENU** key and perform each change operation. If the program is unlocked, the program details (coverslipping speed, volume of mounting medium) can be changed in real time even during coverslipping. Changes made will be saved under the same program number by overwriting the previous settings.

- **Operation to change the cover glass size**
Press the **SIZE** key to change the cover glass size.
- **Operation to change the dispensing volume**
Turn the **VOLUME** dial to change the dispensing volume.
- **Operation to change the coverslipping speed**
Turn the **SPEED** dial to change the coverslipping speed.

CAUTION: Confirm that the displayed CG value matches the cover glass actually placed in the instrument.

Checking the Dispense of Mounting Medium

Press the **PRIME** key to check if mounting medium is dispensed properly. Press and hold the **PRIME** key for 3 seconds, and mounting medium will be dispensed 10 times consecutively. If mounting medium does not come out, clean the nozzle.

OPERATING INSTRUCTIONS

Placing Slides in a Basket

1. Prepare slides to be coverslipped. Check the stainer station layout and prepare an appropriate basket (20-slide basket or 10-slide basket) as well as a basket adapter appropriate for the basket.
2. Attach the basket adapter to the basket in such a way that the "UP SIDE" mark shown on the top of the adapter faces the same direction as the "UP SIDE" mark shown on one side of the basket. After confirming that the two "UP SIDE" marks are facing the same direction, tilt the basket adapter along the groove (Figure 4-H).
3. Next, place the slides into the basket one by one. Set the slides in the correct orientation so that their tissue side aligns with the "UP SIDE" marks. When all slides have been placed, return the tilted basket adapter to the original position.

CAUTION: Use of deteriorated, worn, damaged or deformed baskets and basket adapters can cause problems. Do not use any of these baskets and basket adapters and change deteriorated, worn, damaged, or deformed baskets/adapters with new ones.

CAUTION: Make sure slides are placed in the basket in a balanced manner. If slides are grouped on one side only, the basket may not be transferred properly during staining operation. When there are only a small number of slides, place them carefully by making sure the basket will not tilt.

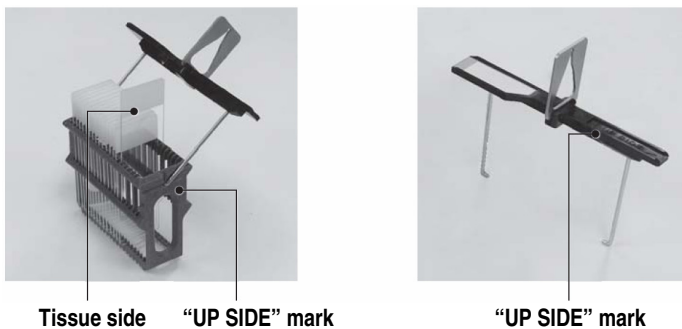

Figure 4-H

CAUTION: Set slides in parallel with the basket partitions. If slides are tilted, they may be damaged (Figure 4-I).

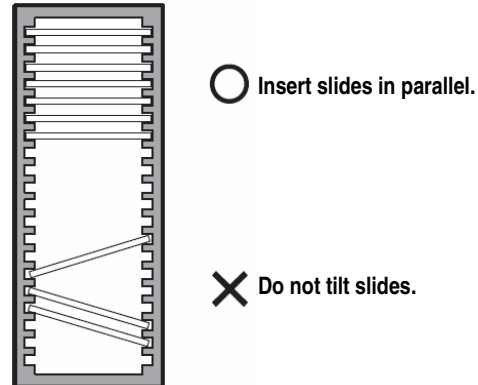

Figure 4-I

CAUTION: If the basket and basket adapters are not aligned with their "UP SIDE" marks facing the same direction, coverslipping may not be performed and the tissues may sustain significant damage. The misaligned basket and basket adapters can also cause the system to fail. Accordingly, confirm that the basket/adapters are aligned properly. If the tissue side of the slide is not facing the same direction as the "UP SIDE" marks, the slide will be coverslipped on the side where tissues are not mounted. This may cause the tissues to sustain significant damage.

Placing a Basket in the Loading Station

1. Confirm that the LOAD lamp on the right side of the control panel is on. While the lamp is not on, baskets cannot be placed.
2. Open the loading station access door, grab the handle, and then slide out the loading station receiver. If the loading station lid is on, remove the lid.
3. Confirm that the loading station is filled with solvent to the specified level (approximately 1.5 L). If there is no solvent or when the solvent level is not sufficient, add solvent.
4. Place the basket in the loading station so that the “UP SIDE” marks on the basket and basket adapter face the right side of the loading station. When placing the basket, be careful not to tilt the basket adapter. If the basket adapter is tilted, the arm may not be able to pick up the basket. The loading station can hold up to 3 slide baskets (Figure 4-J).

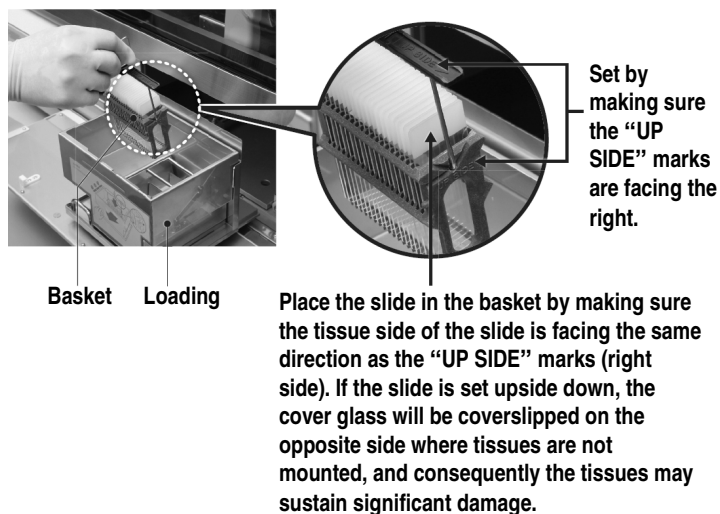

Figure 4-J

5. Push back the loading station receiver into the system and then close the loading station access door (Figures 4-K & 4-L).



Loading station receiver

Figure 4-K



Loading station access door

Figure 4-L

OPERATING INSTRUCTIONS

Starting the Process

After the program has been selected, cover glass, coverslipping speed and volume of mounting medium have been specified, and a basket has been placed, press the **START** key or open and close the unloading station door, depending on the start method selected (see page 3.7). Coverslipping will start and the display will switch to the operation screen.

```
<IN PROCESS> RACK:01
P1:HE-12345 [60mm]
[speed:8 volume:100]
[STOP] to pause
```

Figure 4-M: Operation Screen

The coverslipping process is as follows (Figure 4-N):

1. Slides are picked up from the basket by the slide retrieval arm and placed in station 1, one at a time.
2. Slides are moved to station 2 and mounting medium is dispensed.
3. Slides are moved to station 3 and coverslipped with cover glasses.
4. Slides are moved to station 4 and placed in a receiving rack.
5. When all slides have been placed in receiving racks, the receiving racks are moved to the unloading area.
6. The baskets that have become empty following the processing of all slides are placed in the carousel.
7. If any basket remains in the loading station, the process starts over again. If not, coverslipping ends.



1: Slide retrieval

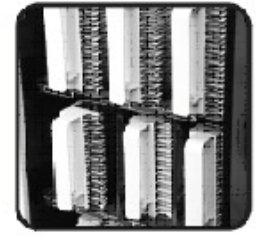

5: Delivery of slide rack into the unloading area

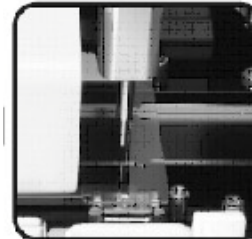

2: Dispensing of mounting medium

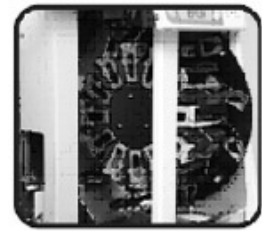

6: Delivery of empty basket into carousel

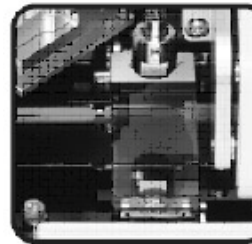

3: Coverslipping



7:



4: Delivery of slide into slide rack

Figure 4-N: The Coverslipping Process

Operations Permitted during Operation

The following operations can be performed during coverslipping.

- Place and remove receiving racks
- Check the program details
- Change the dispensing volume and coverslipping speed (These items can be changed only when the program is unlocked.)
- Pause and resume
- Stop the operation

Placing and Removing Receiving Racks

If the RACK lamp is on during operation, it is possible to place and remove receiving racks in the unloading area.

When the unloading area is opened, the removal screen appears to show which receiving racks have been there for more than the programmed drying time and can be removed.

If “OK” is lit on the right side of a number, the receiving rack corresponding to that number can be removed.

If “OK” is blinking on the right side of a number, the receiving rack corresponding to that number is still being dried (Figure 4-O).

If no drying time is programmed, “OK” is lit next to all numbers.

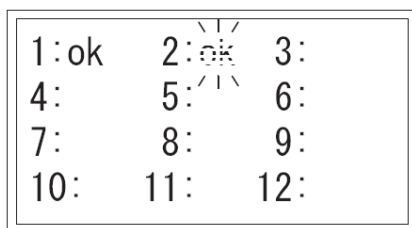

Figure 4-O: Retrieval Screen

In the example shown above, rack 1 has been there for more than the drying time and can be removed. Drying of rack 2 is not yet completed.

CAUTION: After opening the door, remove all completed receiving racks.

Place empty receiving racks and remove receiving racks containing slides while the **RACK** lamp is on. This lamp turns on when the system is stopped or a glass slide is being placed in a receiving rack.

CAUTION: This system returns receiving racks to the positions from which they were retrieved. Accordingly, do not place an empty rack in a position that is empty because the corresponding rack is being filled with slides. Refer to the screen for the available positions.

Checking the Program Details

The current program details are shown in the fourth line when the < and > keys are pressed on the control panel.

Changing the Dispensing Volume and Coverslipping Speed

It is possible to change the dispensing volume and coverslipping speed while the system is processing (assuming the program is not locked) or paused. The new values will be saved under the current program number and reflected in the process.

Change the dispensing volume by turning the VOLUME knob on the control panel.

Change the coverslipping speed by turning the SPEED knob on the control panel.

If either of these settings is changed during processing, the new setting will be in effect from the next slide to be coverslipped.

OPERATING INSTRUCTIONS

Pausing the Process

To pause the process, press the **STOP** key on the control panel. Note that the process cannot be paused during initial priming or while the dispensing tubing is being cleaned.

While the process is paused, it is possible to navigate menu items, remove receiving racks, change the program, change the cover glass size, perform dispense check, change the dispensing volume, change the coverslipping speed, change the mounting medium bottle.

1. Press the **STOP** key.
2. The pause preparation screen appears (Figure 4-P). The process does not stop right away, but will continue until all glass slides currently in the station have been coverslipped and placed in a rack.
3. When the process is completed, the pause screen appears and the system will pause (Figure 4-Q). To resume the operation, press the **START** key. To cancel the operation, press the **STOP** key.

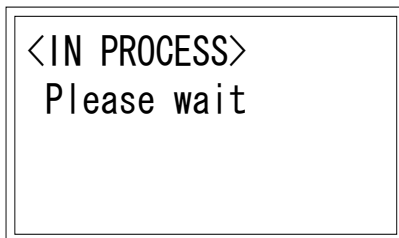

Figure 4-P: Pause Preparation Screen

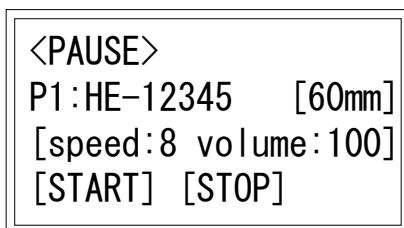

Figure 4-Q: Pause Screen

Resuming the Process

To resume the paused process, press the **START** key. The process will resume. At this time, a caution screen will appear if the loading station access door is open. Close the loading station access door and the process will resume.

Cancelling the Operation

1. To cancel the operation in progress, press the **STOP** key.
2. The pause preparation screen appears. The process does not stop right away, but will continue until all glass slides currently in the station have been coverslipped and placed in a rack.
3. When the process is completed, the pause screen appears and the system will pause.
4. Press the **STOP** key again. The operation stop confirmation screen appears. Press the **ENTER** key to cancel the operation. Press the **EXIT** key to return to the pause screen.

End of Coverslipping

When all slides present in the loading station have been coverslipped and the receiving racks are ready for removal, a sound is output to notify the end of coverslipping. The system will stop, and will display the standby screen on the control panel. Once the system has stopped, remove the receiving racks from the unloading area. Also remove the empty baskets from the carousel.

Removing the Receiving Racks

1. When the system has stopped completely and the RACK lamp on the right side of the control panel has turned on, open the unloading area.
2. Remove the receiving racks containing the slides (Figure 4-R). Receiving racks containing the slides are projecting from the recessed area in the unloading area so that they can be differentiated from empty receiving racks.
3. When all receiving racks have been removed, place empty receiving racks in the recessed area and then close the unloading door.

CAUTION: Before moving the coverslipped slides, keep them horizontal and wait until the mounting medium dries thoroughly. Do not position the slides vertically. If the mounting medium is not dry, the slides may stick to the surfaces.

Removing Baskets

After the system has stopped completely, open the cover and remove the baskets from the carousel (Figure 4-S).

Concaved part in the unloading area



Figure 4-R



Figure 4-S

OPERATING INSTRUCTIONS

End of Operation

This section explains the operating procedure to be carried out after the system operation has ended.

1. Press the "O" side of the power switch to turn off the power.
2. Open the unloading door and check if any processed receiving rack remains. Remove all such racks, if any, and close the unloading door.
3. Open the unloading station access door, grab the handle, and pull out the unloading station receiver. Place the lid on the unloading station, push the unloading station receiver back into the system, and close the unloading station access door.

NOTE: Performing periodic cleaning and maintenance of the system during the above end-of-operation processing allows the system to operate in good condition for an extended period of time.

What to Do before Prolonged Period of Non-operation

If the system will not be used for a prolonged period (one week or more), follow the steps below:

1. Turn off the power switch.
2. Disconnect the system power plug from the power outlet.
3. Open the cover. Remove the cover glass holders and store them in a dry place.

CAUTION: If the cover glass holders are stored in a humid place, they may cause problems, such as allowing two slides to be picked up together, the next time the holders are used.

4. Add solvent to the anti-drying bottle (Figure 4-T).

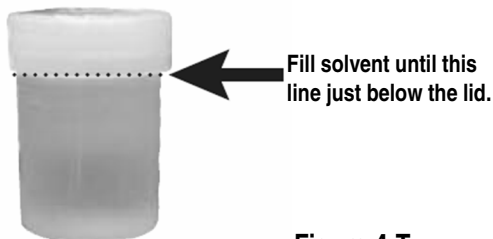

Figure 4-T

5. Push the lever down to the left (Figure 4-U). The dispensing nozzle comes down and its tip dips into the liquid in the anti-drying bottle (Figure 4-V).

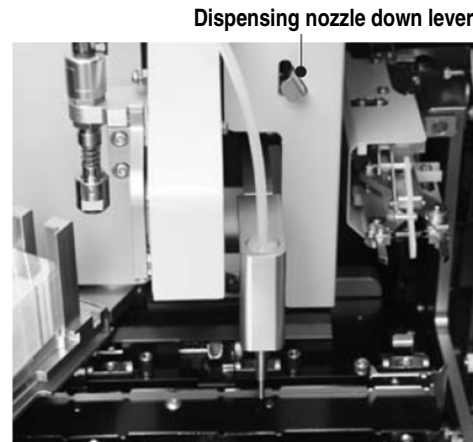

Figure 4-U

6. To prevent mounting medium in the dispense tubing from solidifying, confirm that a mounting medium bottle is placed.
7. Check if a sufficient amount of solvent in the anti-drying bottle.
8. Clean the interior of the system.
9. Close the cover.

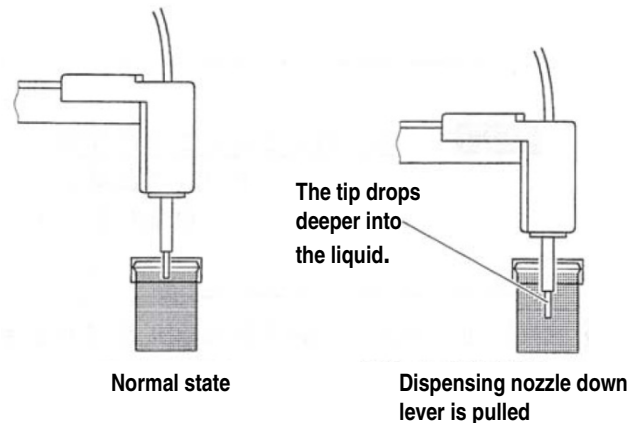

Figure 4-V

Actions to Be Taken upon Power Outage during Operation

This section explains the procedure to be followed when a power outage occurs during operation, as well as the operating procedure to be carried out to reset the system after restoration of power.

Upon Power Outage during Operation

If a power outage occurs during operation, take the necessary action by following the procedure below. In the event of a power outage, even after the power is restored, the operation cannot be resumed from the step the system was performing immediately before the power outage.

1. Press the “○” side of the power switch to turn off the power, in order to prevent the system from moving suddenly upon restoration of power.
2. After the power has been turned off, open all doors and covers and take appropriate actions.
 - Place the slides not yet coverslipped back in the solvent, in order to prevent them from drying up.
 - Remove the cover glasses that have been picked up and dropped around the transfer arm, if any.
 - Remove the receiving rack currently in the receiving position, if any.
3. Close all doors and covers, and wait for the power to restore.

Upon Restoration of Power

After the power has been restored, perform the reset operation by following the procedure below:

1. Press the “|” side of the power switch to turn on the power.
2. Once the power is supplied, the operator action screen appears on the control panel to notify that a power outage had occurred.
3. After confirming that no slides remain inside the system, press the **EXIT** key on the control panel to return to the initial screen.
4. After confirming that the LOAD lamp on the right side of the control panel is on, open the loading station access door, place baskets in the loading station, and then start the operation from the beginning.

CAUTION: The operator action screen notifying the occurrence of power outage also appears after a momentary power failure. In this case, also turn off the system power, remove the half-processed slides and basket, and then start the operation from the beginning.

OPERATING INSTRUCTIONS

Table of Coverslipped Conditions and Operator Actions

To Achieve a Desired Coverslipped Condition

Check the coverslipped slides and if they are not coverslipped in a satisfactory condition, take remedial actions by referring to the table below. For the remedial actions to be taken when two or more cover glasses are picked up together, cover glasses crack when they are picked up, or the like, refer to Section 6, Troubleshooting.

Coverslipped Condition	Cause	Operator Action
Large air bubbles are present on slides.	Not enough mounting medium is dispensed.	Increase the dispense amount of mounting medium.
	Air bubbles have entered the dispensing channel of mounting medium, so mounting medium is not dispensed by the specified amount.	Clear mounting medium channel by using the PRIME key or use initial priming operation to remove air bubbles.
	Mounting medium has run out.	Replace the mounting medium bottle with a full one. If the mounting-medium level detection function is not working, the system must be adjusted. Call the Customer Service Center or the Sakura dealer.
	The cover glass size does not match the applicable settings on the system side.	Change the cover glass size displayed on the screen according to the size of the cover glass used.
	There is not enough or no clearing agent in the loading station.	Fill the loading station with clearing agent up to the specified level. If an appropriate amount of clearing agent is not available, mounting medium may not spread properly on the slide and air bubbles may generate as a result.
	The tissue thickness does not match the applicable settings on the system side (amount of mounting medium, coverslipping speed). Settings for amount of mounting medium and/or coverslipping speed need to be adjusted to compensate for the tissue thickness	Increase the amount of mounting medium. Alternatively, decrease the coverslipping speed and examine appropriate coverslipping conditions again. If the tissues do not have an even thickness, air bubbles cannot be fully eliminated.
Small air bubbles are present.	The coverslipping applicator pressure is too weak and needs to be increased.	Increase the applicator pressure of the cover glass during coverslipping. For details, consult the Customer Service Center or the Sakura dealer.
	Mounting medium did not spread effectively because the ambient temperature was low which increases viscosity and air bubbles entered as a result.	Decrease the coverslipping speed.
	The tissue thickness does not match the applicable settings on the system side (amount of mounting medium, coverslipping speed). Settings for amount of mounting medium and/or coverslipping speed need to be adjusted to compensate for the tissue thickness	Increase the amount of mounting medium. Alternatively, decrease the coverslipping speed and examine appropriate coverslipping conditions again.
	The slide glasses are not of the specified size.	Use slide glasses of the specified type. Specified slide glass: 26 mm (width) x 76 mm (length) x 0.9 to 1.2 mm (thickness) Adjust the system according to the slide glass used. For details, consult the Customer Service Center or the Sakura dealer.
	Mounting medium has solidified on or in the tip of the dispensing nozzle and mounting medium is not being dispensed properly.	Remove the solidified mounting medium.

Coverslipped Condition	Cause	Operator Action
Small air bubbles are present.	Mounting medium is attached to the slide transfer station, causing the slide to not sit properly at the correct angle, so mounting medium is not dispensed properly.	Remove the attached mounting medium by dissolving it using xylene or other solvent. (If the mounting medium has solidified, remove it using tweezers, etc.)
	With certain mounting mediums air bubbles enter if the coverslipping speed is low.	Decrease the coverslipping speed.
	The tip of the dispensing nozzle was soaked for an extended period of time in the anti-drying bottle, so the viscosity of the mounting medium in the tip of the dispensing nozzle has dropped.	Press the PRIME key to dispense the mounting medium.
	The viscosity of the mounting medium in the tip of the dispensing nozzle is high. The amount of solvent in the anti-drying bottle is low.	Press the PRIME key to dispense the mounting medium. Also adjust the amount of solvent in the anti-drying bottle to an appropriate level.
	There is not enough or no clearing agent in the loading station.	Add clearing agent to the loading station up to the specified level. If an appropriate amount of clearing agent is not available, mounting medium may not spread properly on the slide and air bubbles may generate as a result.
	The pressure applying the cover glass during coverslipping is too weak.	Increase the cover glass application pressure. For details, consult the Customer Service Center or the Sakura dealer.
	The starting position of the application of mounting medium not appropriate.	Change the start position for application of mounting medium. For details, consult the Customer Service Center or the Sakura dealer.
	The amount of mounting medium being dispensed is not appropriate.	Change the first dispense amount of mounting medium. For details, consult the Customer Service Center or the Sakura dealer.
	Not enough clearing agent remains attached to the slide (when the slide is retrieved from the loading station).	Increase the slide retrieval speed. For details, consult the Customer Service Center or the Sakura dealer.
	Mounting medium comes out of the slide at the frosted end, etc.	It is normal for mounting medium to come out by several mm or so.
The cover glass size does not match the applicable settings on the system side.		Change the cover glass size displayed on the screen according to the size of the cover glass used.
Too much mounting medium is dispensed.		Decrease the amount of mounting medium dispensed.
Too much clearing agent remains attached to the slide when the slide is retrieved from the loading station.		Decrease the slide retrieval speed. For details, consult the Customer Service Center or the Sakura dealer.
The application pressure of the cover glass during coverslipping is too strong.		Decrease the cover glass application pressure. For details, consult the Customer Service Center or the Sakura dealer.
The starting dispensing position of mounting medium is not appropriate.		Change the start position for dispensing of mounting medium. For details, consult our Customer Service Center or the Sakura dealer.
The amount of mounting medium dispensed during the first dispense is not appropriate.		Change the first dispensing amount of mounting medium. For details, consult the Sakura dealer.
The back of the slide becomes dirty with mounting medium.	Mounting medium from the receiving rack was transferred back to the back of the slide.	Clean the receiving rack with solvent (normally xylene).
	The slide transfer stage is dirty with mounting medium, and mounting medium on the slide transfer stage has attached to the back of the slide during transfer.	Clean the transfer stage with solvent (normally xylene).
	Too much clearing agent remains attached to the slide (when the slide is retrieved from the loading station).	Decrease the slide retrieval speed. For details, consult the Customer Service Center or the Sakura dealer.

OPERATING INSTRUCTIONS

Coverslipped Condition	Cause	Operator Action
The back of the slide becomes dirty with mounting medium.	The application pressure of the cover glass during coverslipping is too strong.	Decrease the cover glass application pressure. For details, consult the Customer Service Center or the Sakura dealer.
	The starting dispensing position of mounting medium is not appropriate.	Change the start position of dispense of mounting medium. For details, consult the Customer Service Center or the Sakura dealer.
	The amount of mounting medium dispensed is not appropriate.	Change the dispensing amount of mounting medium. For details, consult the Customer Service Center or the Sakura dealer.
	The drying fan is not operating.	The system must be adjusted. Contact the Sakura dealer.
	Mounting medium of low viscosity was used.	Use mounting medium with a viscosity of approx. 500 cps.
The mounting position on the cover glass position deviates.	The suction pads on the cover glass arm are dirty.	Clean the suction pads.
	The system is not leveled horizontally.	Use the adjusters on the system to level the system to the installed state. For details, consult the Customer Service Center or the Sakura dealer.
	Too much clearing agent remains attached to the slide (when the slide is retrieved from the loading station).	Decrease the slide pickup speed.
	The drying fan is not operating.	The system must be adjusted. For details, consult the Sakura Customer Service Center or the Sakura dealer.
	The cover glass holder does not match the cover glass size.	Set cover glasses in cover glass holders of an appropriate size.
	The screws on the pedestal of the cover glass holder are loose.	The screws must be tightened. For details, contact the Sakura dealer.
	The cover glass made contact with the receiving rack when the coverslipped slide was placed in the receiving rack, altering the mounting position	The position of the receiving rack must be adjusted. For details, contact the Sakura dealer. Take note that if the tissues are extremely thick, they may not be fully accommodated in the receiving rack and consequently their mounting position on the cover glass may deviate. Refrain from automatically coverslipping tissues when the slide thickness (slide glass + tissues + mounting medium layer + cover glass) becomes 2 mm or more.
The cover glass is not covering the tissues on the slide.	The cover glass is too small.	Change the cover glasses to a larger size.
	The tissue mounting position on the slide is too high or too low.	Make sure the position at which tissues are mounted on the slide glass corresponds with the indicated center of the cover glass. (Refer to "Notes on Use" in Appendix C, page C.1). Select an appropriate type of cover glass according to the tissue mounting position.
	The slide is set upside down in the basket.	Make sure the frosted part is facing up.
	The slide is set front-side backwards in the basket.	Make sure the tissue side of the slide is facing the "UP SIDE" mark on the basket.
The cover slide and slide are not coverslipped parallel.	The cover glass size does not match the applicable settings on the system side. The width is different from the specified value.	Use the specified cover glass.
	The system is not adjusted properly.	The system must be adjusted. For details, consult the Customer Service Center or the Sakura dealer.
Suction pad marks remain on the cover glass.	The suction pads on the cover glass arm are dirty.	Clean the suction pads.

How to Operate the g2 when Linked to the Prisma Tissue-Tek® Prisma® Slide Stainer

This section explains how to set up the Prisma when the g2 is linked to the Prisma.

How to Set Up the Prisma

1. Select the menu in the bottom right-hand corner of the Prisma control panel, and then select the Utility menu tab (Figure 4-W).

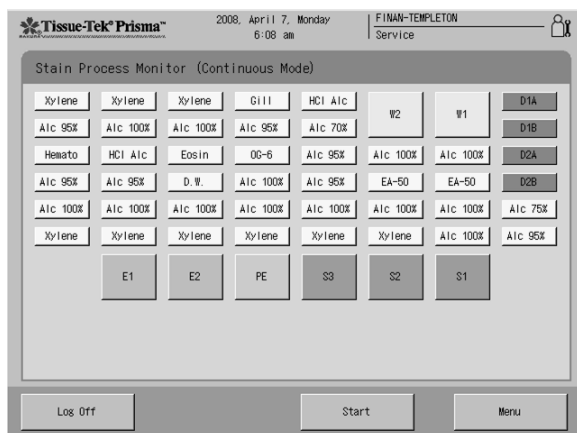

Figure 4-W

2. Select **System Setup** in the Utility menu (Figure 4-X).

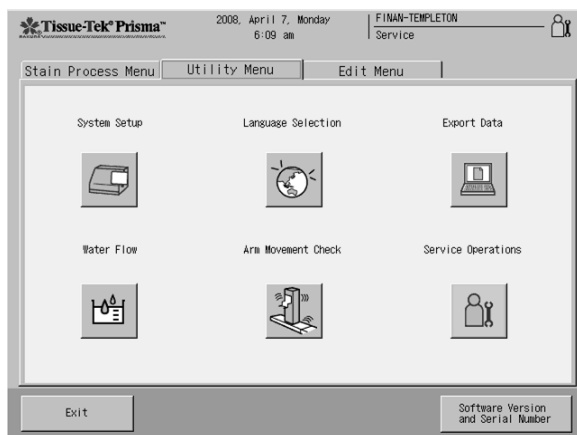

Figure 4-X

3. Select **In Use** under Coverslipper Link, and select **Tissue-Tek Glas** under Coverslipper (Figure 4-Y).

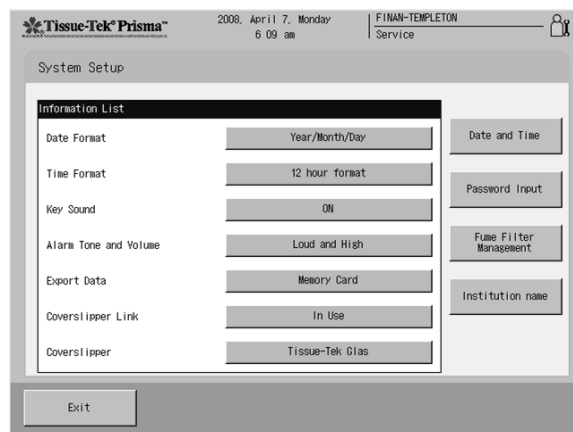

Figure 4-Y

4. Press the **EXIT** key and select the Stain Process menu tab.
5. In the Stain Process menu, select **Staining Mode Selection** (Figure 4-Z).

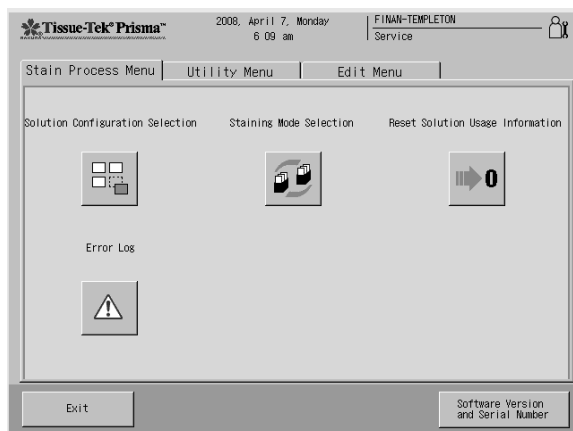

Figure 4-Z

OPERATING INSTRUCTIONS

- Confirm that **Yes** is selected for Link With Coverslipper in the System Setup tab (Figure 4-AA).

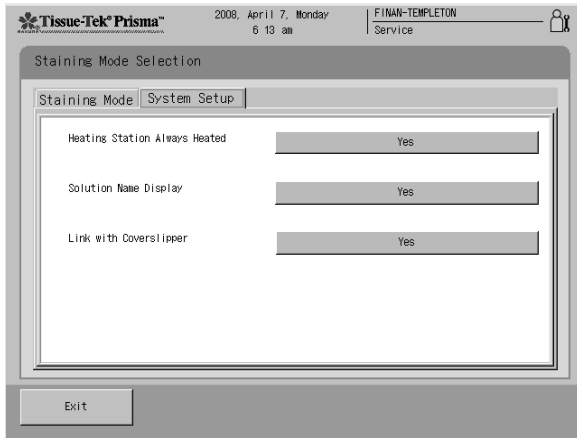

Figure 4-AA

- Press the **EXIT** key to return to the monitor screen.

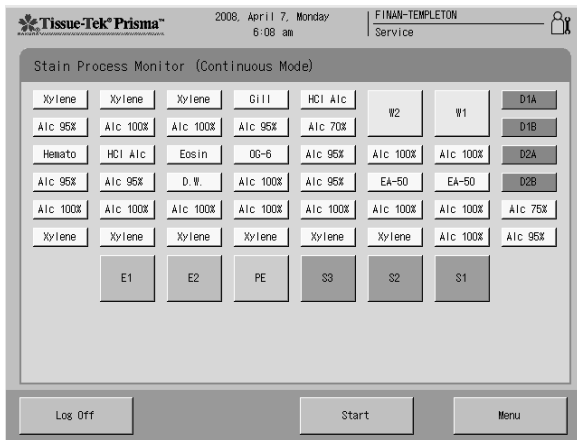

Figure 4-BB

- Confirm that the link station (LK) is displayed in the bottom left-hand corner of the station view.

How to Start from the Prisma

- Press the **START** key on the monitor screen.
- When the display switches to the process start screen (Figure 4-CC), select a staining program and a coverslipping program. When the program number setting key is pressed on the coverslipper, the numeric keypad screen appears (Figure 4-DD). Use the numeric keypad to enter the program number to be used by the coverslipper. "0" is entered by default. If the default setting is used, coverslipping will be performed according to the conditions currently displayed on the coverslipper.

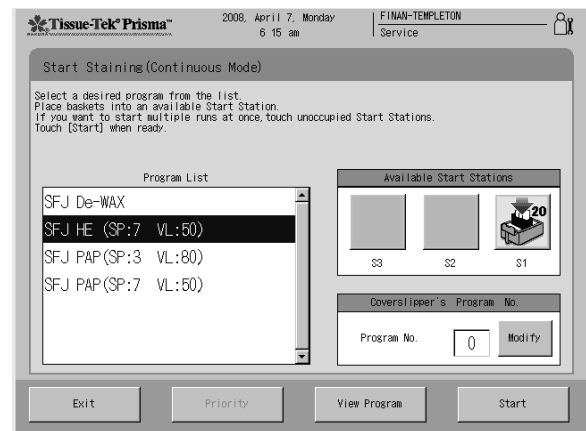

Figure 4-CC

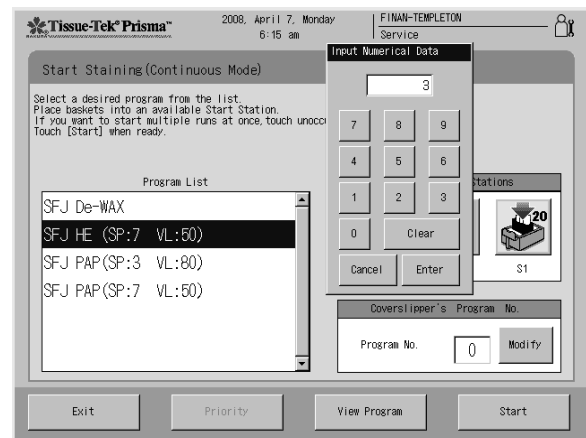

Figure 4-DD

- Press the **ENTER** key on the numeric keypad to confirm the coverslipping program, and confirm that the program number has been changed (Figure 4-EE). Set (save) a coverslipping program for each staining program. When setting a coverslipping program, make sure the applicable program is already programmed on the coverslipper side.

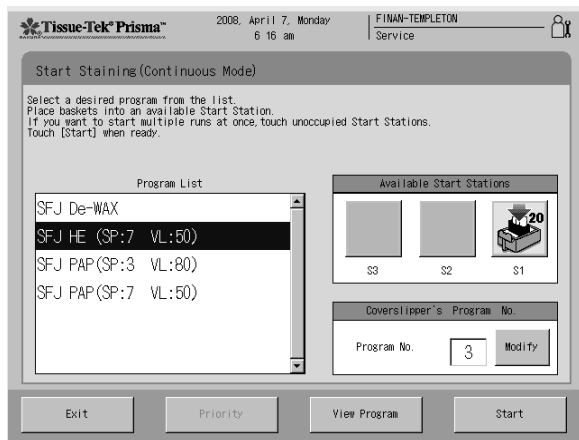

Figure 4-EE

- Open the Prisma loading station access door, place baskets in the specified loading station, and close the door (Figure 4-FF).

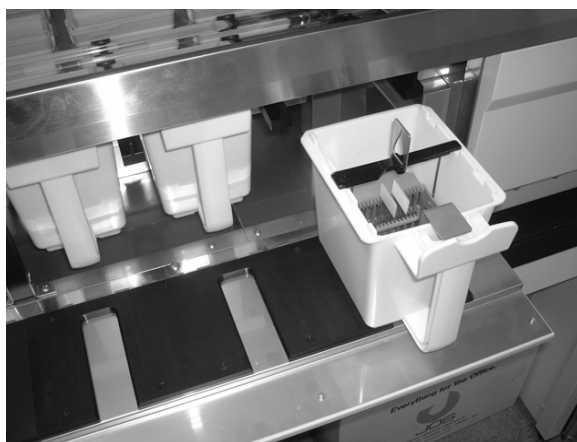

Figure 4-FF

- After confirming the staining program and the loading station where the baskets have been placed, press the **START** key to start the process (Figures 4-GG & 4-HH).

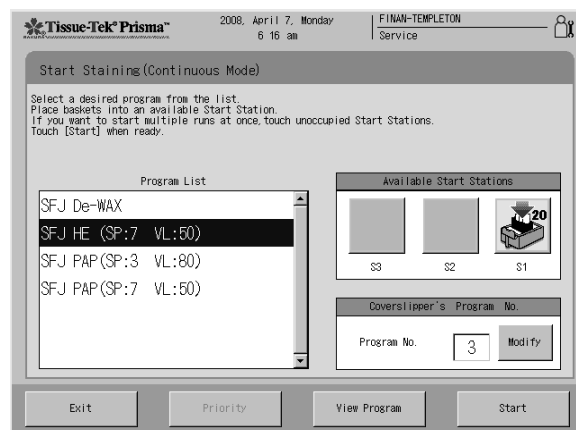

Figure 4-GG

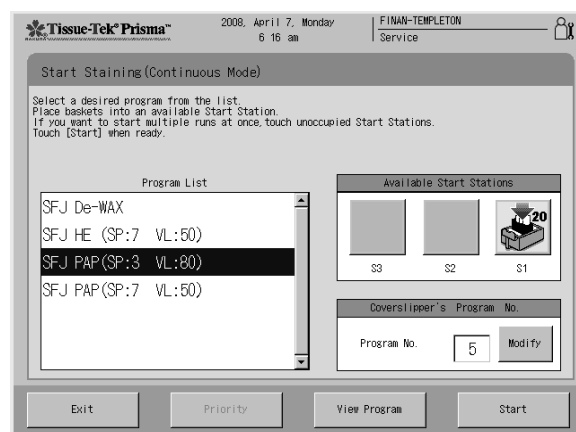

Figure 4-HH

WARNING: MAKE SURE THE SLIDES ARE EVENLY STORED IN THE BASKET. IF THE SLIDES ARE STORED UNEVENLY, THE BASKET MOVEMENT IS AFFECTED DURING THE STAINING OPERATION. TAKE SPECIAL CARE WHEN THERE ARE ONLY A SMALL NUMBER OF SLIDES. STORE THEM CAREFULLY TO PREVENT THE BASKET FROM TILTING.

OPERATING INSTRUCTIONS

CARE OF THE INSTRUMENT

General Maintenance

Keep the exterior of the instrument free of dust at all times. If needed, the exterior may be cleaned using a damp cloth and a mild detergent; do not use solvents of any kind on the painted exterior parts. The plastic cover may be cleaned with a glass cleaner and soft cloth.

Inspection Methods and Cleaning

To prevent system malfunctions and failures, inspect and clean the system regularly. Unless otherwise specified in this manual, carry out all inspection and cleaning tasks with the power turned off.

Cleaning Each Station and Waste Container

Clean each station and its surrounding area, as well as each waste container, at the end of each day.

1. Open the cover.
2. Brush off each station and its surrounding area and remove dirt and all other foreign matters by collecting them in one location. If it facilitates the process, use adhesive tape to remove foreign matters.
3. Dissolve and remove mounting medium attached around the stations using a cloth moistened with solvent for mounting medium. If mounting medium has already solidified, remove it using tweezers. Also remove any glass powder. If mounting medium or glass powder attaches to any moving part and subsequently solidifies, an unexpected error or failure may occur.
4. Use a cloth moistened with alcohol to remove oil from the cover glass contacting surfaces of the suction pads on the cover glass arm, and dry the pads.
5. Follow the procedure below to clean the tip of the dispensing nozzle:
 - While lifting the dispensing nozzle, move the nozzle toward the back.
 - With the dispensing nozzle still lifted, wipe the tip using a lint-free cloth.
 - Pull out the dispensing nozzle while it is still lifted, and insert its tip into the anti-drying bottle.

6. Remove each waste container and replace it with a clean container.
7. Check the spatula part of the removed waste container for deformation or damage. When spatula part is deformed or damaged, replace the waste container with a new container. The spatula of the waste container functions as a drain board for mounting medium at the tip of the dispensing nozzle. If the spatula does not function properly as a drain board, dispensing may be affected.
8. Put solvent for mounting medium in a container and soak the waste container in the solvent for 24 hours to dissolve the attached mounting medium.
9. Remove the waste container and let it dry completely.
10. Close the cover.

Changing Solvent in the Anti-drying Bottle

Change the solvent for mounting medium remaining in the anti-drying bottle with fresh solvent once a week or whenever the solvent in the anti-drying bottle becomes cloudy.

NOTE: Solvent for mounting medium in the anti-drying bottle gets cloudy over time as it is mixed with mounting medium. If the solvent becomes cloudy, the function of the anti-drying bottle, which is to prevent the tip of the dispensing nozzle from drying, may be less effective.

1. Open the cover.
2. Remove the anti-drying bottle while lifting the dispensing nozzle (Figure 5-A).

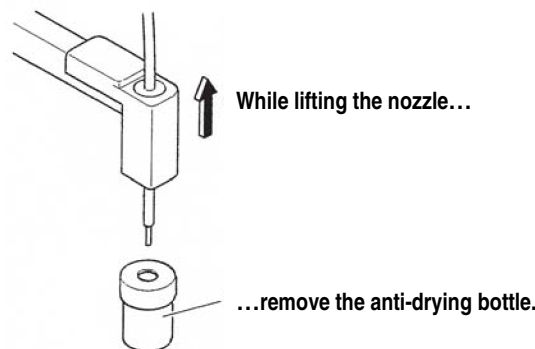

Figure 5-A

CARE OF THE INSTRUMENT

3. Drain solvent from the anti-drying bottle and add fresh solvent for mounting medium up to the position shown below (Figure 5-B).
4. Return the anti-drying bottle to its original position and close the cover.

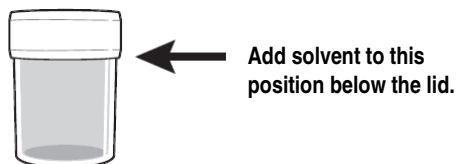

Figure 5-B

Cleaning the Receiving Rack

If the slides are dirty or placed at an angle, mounting medium may be attached the receiving racks (slide racks). Clean each receiving rack once a week or whenever it becomes dirty due to attached mounting medium.

1. Put solvent for mounting medium in a container made of a material resistant to the solvent, and soak the receiving rack in the solvent for 24 hours to dissolve the attached mounting medium.
2. Remove the receiving rack and let it dry completely.

Cleaning the Loading Station

Tissue fragments, glass powder and other foreign matters collect in the loading station. Accordingly, clean the loading station once a week.

1. Drain solvent from the basket container.
2. Disassemble the loading station. For the disassembly method, refer to "Installing the Loading Station."
3. Clean the disassembled parts with a brush or toothbrush by applying the same type of solvent being used in the system.
4. Assemble the loading station.

CAUTION: To minimize contamination, change or filter the solvent in the loading station at the end of each working day.

Adding/Changing Solvent in the Dispensing Pump Reservoir

The dispensing pump reservoir is used to prevent the dispensing pump in the system from locking due to mounting medium. Add solvent if the remaining solvent level drops below the midway point between the shoulder of the reservoir and the line indicating the minimum level. Also change the solvent in the reservoir at least once every two months.

1. Open the cover and remove the lid of the dispensing pump reservoir. To add solvent and go to step 3. To change solvent, go to step 2.
2. To change solvent, suction out solvent from the dispensing pump reservoir using a pipette.
3. Add solvent for mounting medium up to the shoulder of the dispensing pump reservoir.
4. Place the lid on the dispensing pump reservoir and close the cover.

Cleaning the Slide Arm

Clean the slide arm and slide detection sensor once a week or whenever they become visibly dirty. If the slide arm has become worn or starts experiencing problems picking up slides, the slide arm must be replaced. Contact the Sakura Customer Support Department or the local Sakura distributor.

1. Open the cover.
2. Clean the slide arm and slide detection sensor using a cloth moistened with alcohol.

TROUBLESHOOTING

General Information

The following section explains how to recover from conditions that may occur during routine operation. A Troubleshooting Table is provided, which identifies possible conditions related to the electrical and mechanical operations that could occur during routine operation of the Tissue-Tek® Glass™ g2 Coverslipper. Possible causes and remedies are also included so that many isolated problems can quickly be corrected. When dealing with any problem, it is essential to determine which part of the system is the source. A systematic approach should be employed to isolate the problem.

If additional assistance is required concerning an instrument problem, or if the problem cannot be isolated or is beyond the scope of this manual, please contact the Technical Support Department by calling (800) 725-8723, option 2 (U.S. only) or call the local Sakura distributor.

TROUBLESHOOTING

Troubleshooting Table

Check the possible problem conditions listed in the table below and if any of them applies to the problem that has occurred, take the specified action or actions. If the problem persists or when none of the listed conditions applies, contact the Sakura dealer.

System condition	Cause	Remedial action
Nothing is displayed.	The power is not turned on.	Turn on the power.
	The power plug is disconnected.	Connect the power plug.
	The power is not supplied.	Check the breaker on the facility side.
	The system power was cut off temporarily (= momentary power failure).	Turn off the system power and then turn it back on.
Mounting medium is not dispensed.	The mounting medium bottle is empty.	Replace the mounting medium bottle or add mounting medium to the specified level or more. If the mounting-medium level detection function is not working, the equipment must be adjusted. Contact the Customer Service Center or the Sakura distributor.
	Mounting medium at the tip of the dispensing nozzle has solidified.	Dissolve the solidified mounting medium using solvent (usually xylene). For details, consult the Customer Service Center or the Sakura distributor.
The system suddenly stopped operating.	A power outage occurred.	Take a remedial action according to "Actions to Be Taken upon Power Outage during Operation" in Section 4.
Cover glasses cannot be taken out or they dropped during coverslipping.	The suction pads on the cover glass arm have deteriorated or are damaged.	Replace the suction pads on the cover glass arm with new ones. Contact the Customer Service Center or the Sakura distributor.
	Cover glasses are not stored in an appropriate environment.	Store cover glasses in a place not subject to high humidity. If stored in a humid place, cover glasses may stick together easily.
	Old cover glasses were used.	Use new cover glasses. Old cover glasses may stick together easily.
Two or more cover glasses are coverslipped together.	Cover glasses are not stored in an appropriate environment.	Store cover glasses in a place not subject to high humidity. If stored in a humid place, cover glasses may stick together easily.
	Old cover glasses were used.	Use new cover glasses. Old cover glasses may stick together easily.
	The type of cover glasses used or the angle by which the cover glass is lifted is not appropriate.	Increase the cover glass lifting angle.
	Cover glasses used are not specified for automatic coverslippers.	Use cover glasses specified for automatic coverslippers.
Cover glasses get cracked.	The type of cover glasses used or the angle by which the cover glass is lifted is not appropriate.	Decrease the cover glass lifting angle.
An empty receiving rack is not picked up.	The receiving rack is not set in the specified position correctly.	Set the receiving rack properly in the concaved part of the unloading area.
	The receiving rack is damaged.	Contact the Customer Service Center or the Sakura distributor.
The processing capacity drops and every other slide is skipped. (The CG size on the screen is blinking.)	The cover-glass level detection function was actuated, and the system switched to the slide pickup mode only after a cover glass was detected.	Press the STOP key and add cover glasses, and the original processing capacity should be restored. If coverslipping is continued without taking the above action, the cover glass count will drop to 0 and a "No cover glass" error will generate.
A receiving rack containing coverslipped slides remains during operation, but "OK" is not displayed on the screen.	When the unloading door was opened, not all receiving racks whose drying time had elapsed (for which "OK" was lit) were taken out.	Open the unloading door, take out all receiving racks containing coverslipped slides and whose drying time has elapsed, and then close the unloading door.

Actions to Take upon Generation of Errors, Cautions, and Warnings

When an error occurs, an alarm will sound immediately to alert the operator of the abnormality. If coverslipping is still possible, the system will wait until the current process is completed and then display the error screen. Do not touch the system until the error screen appears.

Representative message screens that will appear upon generation of various errors are shown below. Follow the message on the screen to perform up to four steps, remove the slides handled in the current process, and then reset the error.

1. When the error screen below appears (Figure 6-A), be sure to remove all slides on the transfer stage and then press the **ENTER** key. Store the removed slides in a manner preventing them from drying up, and process them together later on. The removed slides cannot be returned to the baskets in the loading station.

```

<ERROR>          EXXX
MOTOR: XXXX
Remove slides
[ENTER]for next step
    
```

Figure 6-A

2. When the error screen shown below appears (Figure 6-B), press the **ENTER** key. If the arm is currently gripping a slide, pull out the slide before pressing the **ENTER** key. Store the removed slides in a manner preventing them from drying up, and process them together later on. If the arm failed to grip a slide, press the **ENTER** key immediately.

```

<ERROR>          EXXX
If a slide is on
the gripper, remove
[ENTER] to next step
    
```

Figure 6-B

3. When the error screen shown below appears (Figure 6-C), retain the cover glass currently being picked up by the suction pads and then press the **ENTER** key. The cover glass will be released the moment the **ENTER** key is pressed.

```

<ERROR>          EXXX
MOTOR:Z slide rack
[ENTER] to release
a cover glass
    
```

Figure 6-C

4. When the error screen below appears (Figure 6-D), remove receiving rack from rods by lifting upward to unhook it. Then press the **ENTER** key.

```

<ERROR>          EXXX
Remove the rack
from the hook
[ENTER]for next step
    
```

Figure 6-D

- When slides are in the receiving rack, open the cover, and carefully remove the receiving rack by raising the rack upward and tilting the rack back towards the left as it is being pulled out so that the slides do not drop out.
- When a rack is being retrieved or unloaded (when racks are in the unloading area) remove from the area number indicated on screen or visually associated with the position of the rods attached to the robotic arm.
- If rack is still hooked on to the rods, unhook the rack by lifting upward and tilting the rack slightly back to the left so that the slides do not fall out.
- It might be necessary to reach behind the receiving area to remove a rack hooked onto the rods.

TROUBLESHOOTING

GLOSSARY

Glossary of Terms

40-mm CG:

A cover glass with a length of 40 mm.

50-mm CGC:

A cover glass with a length of 50 mm.

55-mm CG:

A cover glass with a length of 55 mm.

60-mm CG:

A cover glass with a length of 60 mm.

CG:

An abbreviation for "Cover Glass."

SG:

An abbreviation for "Slide Glass."

Cover glass lifting angle:

When the coverslipping arm lifts each cover glass, it does so at an angle so that multiple cover glasses will not be picked up together. This angle is called the "cover glass lifting angle."

Anti-drying:

To prevent the tip of the dispensing nozzle from clogging due to mounting medium.

Slide:

A glass slide on which tissues have been pasted.

Storing:

To move a coverslipped slide into a receiving rack.

Coverslipping:

To attach a cover glass using mounting medium.

Solvent:

A liquid used to dissolve mounting medium. Xylene is mainly used for this purpose.

Dispense:

Dispensing also means applying mounting medium onto a slide as if to draw a straight line.

Basket:

A staining basket holding slides that have not yet been coverslipped.

Receiving rack:

A rack for holding slides that have been coverslipped.

Loading station:

A container in which baskets are placed. Solvent is filled in the loading station to prevent tissues from drying up.

Unloading area:

An area where 12 receiving racks (3 rows x 4 levels) are placed.

Carousel:

A disc-shaped storage area for receiving empty baskets.

APPENDIX A

WARNINGS AND CAUTIONS

Warnings

Do not bring fire sources close to the system. This system uses organic solvent that may ignite upon contact with fire. Do not bring a fire source within 2 m of the system.

Do not bring fire sources close to the activated carbon filters. The activated carbon filters may explode upon contact with fire. Do not bring a fire source within 2 m of the activated carbon filters.

Do not disassemble or modify the system. The system may malfunction or cause an accident.

Do not open covers and doors unless necessary. If the operator must open a cover and insert a hand into the system, do so only after confirming that the system has stopped and the internal components can be operated safely.

If a door must be opened and a basket set, do so only after confirming that the LOAD lamp is on and the internal components can be operated safely. The system is designed to stop when a cover is opened. However, the actual operation may not stop until the series of steps comprising the operation is completed. Touching the system while it is still operating may result in injury.

When opening/closing any cover, be careful not to pinch your hand. Be careful not to pinch your hand between the fixed and moving parts of a cover or between a cover and a door, etc. Your hand may be pinched and injured.

Do not wet the system. Wetting any part of the system other than those specified in Section 5, "Care of the Instrument" or other applicable sections may cause fire or electric shock due to leak current.

Do not operate the switches and connect/disconnect the power plug with wet hands. Doing so may result in electric shock.

Connect/disconnect the power plug by holding the plug. Connecting/disconnecting the power plug by holding any other part other than the plugs may result in fire or electric shock.

Do not forcibly bend, pull, twist or loop the power cable. Use of a damaged power cable may result in fire or electric shock. Should any damage or other abnormality on the power cable or plug be found, contact the Sakura dealer.

Handle reagents (organic solvents) with due care. Some reagents (organic solvents) used by this system may be toxic or harmful to the human body. Accordingly, handle these reagents with due care to prevent them from spilling or scattering. Dispose of reagent properly by following the applicable regulation or guideline in your country or region.

APPENDIX B

Cautions

Provide sufficient airing and ventilation around the system. This system uses solvent (organic solvent) that is toxic and harmful to the human body. Provide sufficient airing and ventilation around the system.

Close the lids on containers during operation. Some reagents (organic solvents) used by this system may be toxic or harmful to the human body. If containers of these reagents remain without lids for many hours, organic gases may fill up the room.

Turn off the power before performing cleaning. Cleaning the system while the power is supplied may result in unexpected accidents.

Connect the power plug to a power outlet with grounding terminal. Connect the power plug to a power outlet with grounding terminal conforming to at least the Class D (former Class 3) grounding specification. If the system is not grounded, fire or electric shock may result due to leak current.

In the event of system malfunction, turn off the power and then disconnect the power plug from the power outlet. In the event of system malfunction, turn off the power and contact the Sakura Service Center. Disconnecting the power plug from the power outlet is one way to cut off the main system power. In the event of abnormality, disconnect the power plug from the power outlet. When installing the system, select a suitable location where the power outlet will not be concealed and the power plug can be disconnected immediately in case of emergency.

Ask the dealer to install or relocate the system. Installation of the system by people having no expert knowledge of the system may result in unexpected accidents.

Do not remove the warning/caution labels. Without these labels, the operators cannot be reminded of the necessary warning/cautionary information in the day-to-day handling of the system, which may result in unexpected problems.

Do not touch the moving parts of the system. Touching moving parts while the system is operating may result in injury.

Inspect the system once every six months. Conduct a periodic inspection every six months to ensure that the system will be used safely and continue to demonstrate the desired performance. Contact the Sakura dealer for the details of periodic inspection.

Exercise due caution when handling reagent. Wear gloves, mask and/or safety goggles or take other proper measures designed to protect the operator, by following the applicable regulation or guideline in your country or region. Some reagents are toxic and harmful to the human body.



If any substance that presents biological hazards is handled, ensure safety by following the applicable regulation or guideline in your country or region.

NOTES ON USE

Notes on Use

Read this “Notes on Use” section beforehand to ensure the correct use of the system. This section explains the items that should be heeded to prevent system failures, as well as items that should be noted to perform proper coverslipping operation.

Cautions for Preventing system Failure

Do not place any object on the system.

Doing so may result in unexpected problems.

Do not place any object on a moving part.

Doing so may result in system failure.

Do not spill any organic solvent onto the system.

Do not use toluene. Use of toluene may cause system malfunction or failure.

Use designated consumable parts. Use of any other consumable part may result in malfunction or system failure.

Do not block the exhaust outlet. When the exhaust outlet on the left side at the rear of the system is blocked, fumes may not be exhausted properly.

Do not use any ultraviolet sterilizing lamp around the system. Ultraviolet light may cause the system characteristics to change or deteriorate.

When opening/closing a cover or door, do so slowly. If large impact is applied to a cover or door, the cover/door may be damaged.

Avoid using a deteriorated or damaged basket or receiving racks. Doing so may result in malfunction or failure.

Do not open any cover or door unless necessary. Open each cover or door only when required in the applicable operation specified in this manual. Once opened, the cover/door should be closed as soon as the operation is finished.

APPENDIX C

Notes for Proper Coverslipping Operating

Put a sufficient amount of clearing agent (mainly xylene) in the loading station to prevent tissues from drying up.

Determine the operating conditions after a coverslipping test. The operating conditions of the system vary depending on the tissues on the slide. Conduct a physical coverslipping test using the system before determining the operating conditions.

Paste tissues at the center of the pasting position on the cover glass. This system does not provide a function for checking the position of pasted tissues on the glass slide. When pasting tissues on the glass slide, make sure tissues are aligned at the center of the cover glass (indicated by *) by taking into account the settings of the cover glass used.

The shaded area indicates the pasting position on each cover glass.

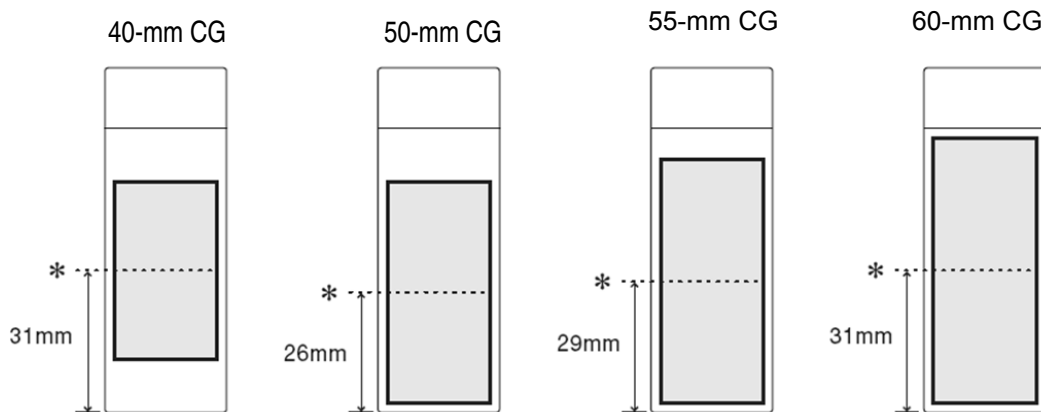

If very thick tissues are coverslipped in some positions, the cover glass may not be stored in the receiving rack properly. Do not use very thick tissues with this system.